

DELLA®

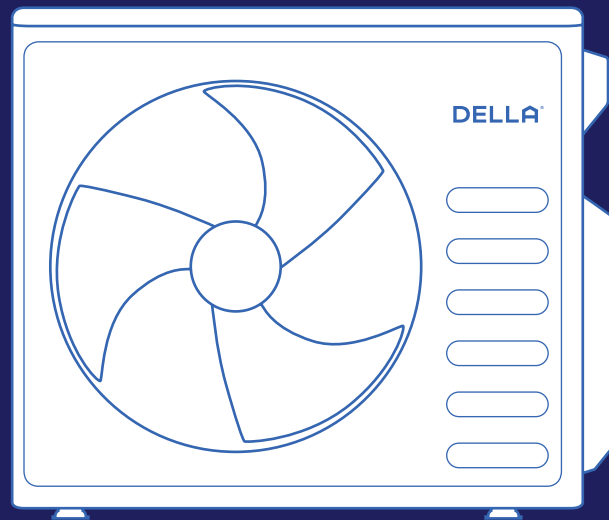

TPH Series Multi-Zone Inverter



Instruction Manual
Installation Guide



Watch video
before Installation

Welcome to **DELLA**[®]

5 Things to know before installation

Thank You for trusting Della as your home comfort solution. We know no better how exciting it must be to have a new and functional AC to make your living space more comfortable. But AC installation, in reality, is far from being simple. Here are a few things you must know before installing the AC whether by yourself or by a professional HVAC technician. This will give you an idea of what to look out for installing an AC so that it can perform at its maximum efficiency and every dollar you invest in it pays off.



The installation location is critical

Not all places are created equal. Only proper placement of the AC will maximize efficiency while balancing the interior aesthetic. As wall requires for the installation, you need to make sure to get the placement and location right the first time.



Handle the refrigerant pipes perfectly

The refrigerant pipe is one of the most important, if not the most important, parts of the mini split AC system. So, be sure to understand what the entire process entails. You might need special-purpose tools to shorten and bend the pipe. Purchasing lengthening pipes to match your connection might also be necessary. Any flow in the handling of the refrigerant pipes may cause a refrigerant leak or reduced efficiency. The cost to repair or re-install the refrigerant pipe can quickly frustrate and upset any DIYer, especially when trying to save money by not hiring a professional. Additional refrigerant might also be needed if you used lengthening pipes or find any leaks during your install. Further more, it's always a good idea to test for any refrigerant leaks after completing your installation by using soapy spray or professional detector tools. Please contact us if you need extra refrigerant.



Bundle the line set correctly

The line set contains the refrigerant pipes, drain hose, and electrical wires. A good bundling prevent water condensation and protects it from external elements, as well as matching the exact distance of the installation. No one wants extra line set dangling around.



Vacuum pumping the refrigerant circuit

Mini-split AC absolutely needs vacuum pumping in order to perform efficiently and prevent refrigerant from reacting with air moisture and damaging the internal parts of the machine. With a vacuum pump and a micron gauge, the process does not take very long, but it is important to do it right.



Safe electrical connection

A safe and properly electrical connection is crucial necessity for the installation. The voltage, power breaker protection, cable requirement and wiring must correspond to the specifications of each model. A poor connection can quickly becomes a fire hazard.



Most of the problems emerge from incorrect or poor installation. Installation performed by professional HVAC technician can greatly reduce the chance of having problems for years to come. On top of that, Della provide extended warranty for professional installation. If you need assistance or have questions, we are here for you.



support.dellahome.com



800-863-4143
6:00 a.m. - 4:00 p.m. PST
Monday - Friday



24/7 Live Chat

Table of Content

Before Installation

Warning and Safety	04
Product Specification	09
- Indoor Unit	09
- Outdoor Unit	10
Compatible Indoor Unit Chart	11
Installation Info	12
- Power Supply and Breaker Size	12
- Refrigerant and Pipe Line Set	14
Choosing Installation Location	15

Wall Mounted Type Indoor Unit Installation

Name of Parts	18
Installation Preview	21
Installation Guide	22
- Wall Hole and Mounting Plate	22
- Drain Hose Connection	24
- Communication Cable Connection	25
- Circuit Diagram	26
- Mounting Indoor Unit	28
- Refrigerant Pipe Connection	29

Outdoor Unit Installation

Name of Parts	34
Outdoor Unit Installation	35
Refrigerant Pipe Connection	38
Electrical Wire Connection	40
Circuit Diagram	42
Vacuum Pumping Guide	46
- 3-6 Zones System Vacuum Pumping	48
- Adding New Indoor Unit Vacuum Pumping	50
Finishing	52
Check List	53
Test Run	54

Warning and Safety

- Read this guide before installation. Failure to follow the safety instructions may result in property damage, serious injury, or death.
- Please Keep this manual.



Danger:
Indicates an IMMEDIATELY hazardous situation that, if not avoided, will result in death, serious injury, or serious property damage.



Warning:
Indicates a POTENTIALLY hazardous situation that, if not avoided, will result in death, serious injury, or serious property damage.



Caution:
Indicates a POTENTIALLY hazardous situation that, if not avoided, will result in minor to moderate injury. It may also be used to indicate unsafe practice.



Attention:
Pay additional attention to the instruction.



DO NOT:
Indicates prohibited actions and / or practice.

About Refrigerant



- The air conditioner is pre-charged with refrigerant. Handle the air conditioner with care and check if there is any refrigerant leakage during installation. Refrigerants have no odor and can be toxic and flammable. Rapid evaporation of refrigerant may cause frostbite, cardiac arrhythmia, and / or irritation, as well as cause environmental damage.



- In the case of refrigerant leakage, shut down the appliance and disconnect from the power supply. An inspection must be performed by a qualified technician.

Additional Information About R454B Refrigerant



- In UL/CSA 60335-2-40, R454B refrigerant is classified as class A2L, which is mildly flammable. Therefore, R454B refrigerant is suitable for system needing additional refrigerant charge and which will limit the area of the rooms being served by the system. Similarly, the total amount of refrigerant in the system shall be less than or equal to the allowable maximum refrigerant charge. The allowable maximum refrigerant charge depends on the area of the rooms being served by the system.
- For R454B refrigerant, the maximum charge in a room shall be in accordance with the following:
 - $M_{max} = SF \times LFL \times h_o \times A$
 - or the minimum floor area A_{min} to install an appliance with refrigerant M_c (kg) shall be in accordance with:
 - $A_{min} = M_c / (SF \times LFL \times h_o)$
 - M = Mass
 - M_{max} = Maximum charge mass
 - M_c = Mass charged
 - A = Floor area
 - LFL = Lower Flammable Limit, for R454B LFL is $0.296 \text{ kg} / \text{m}^3$

Warning and Safety

Additional Information About R454B Refrigerant



- The minimum opening area for connected rooms. $M_c = 1.73\text{kg}$ as an example.

A (m ²)	M_c (kg)	M_{max} (kg)	A_{nvmin} (m ²)
4	1.73	1.48	0.0058
7	1.73	2.59	0.0000
10	1.73	3.70	0.0000
15	1.73	5.55	0.0000
20	1.73	7.4	0.0000
30	1.73	11.1	0.0000

- When the unit detects a refrigerant leak, the minimum airflow of the indoor unit is as follows:

Model	Minimum Airflow	
9K	65 CFM	110 m ³ /h
12K	135 CFM	230 m ³ /h
18K	224 CFM	380 m ³ /h
23K	265 CFM	450 m ³ /h

- Maximum Charge (kg)

Refrigerant	LFL (kg/m ³)	h_o (m)	Floor Area (m ²)						
			4	7	10	15	20	30	50
R454B	0.296	2.5	1.48	2.59	3.70	5.28	6.10	7.47	9.65
		2.8	1.66	2.90	4.14	5.92	6.83	8.37	10.81
		3.0	1.78	3.11	4.44	6.36	7.32	8.97	11.58

Refrigerant	LFL (lb/ft ³)	h_o (ft)	Floor Area (ft ²)						
			43	75.3	107.6	161.4	20	30	50
R454B	0.0185	8.2	15.9	27.9	39.8	56.8	65.7	80.4	103.9
		9.2	17.9	31.2	44.6	63.7	73.5	90.1	116.4
		9.8	19.2	33.5	47.8	68.5	78.8	96.6	123.6

Warning and Safety

Additional Information About R454B Refrigerant



- Minimum Room Area (m²)

Refrigerant	LFL (kg/m ³)	h ₀ (m)	Charge Amount (M)						
			0.71 kg	0.8 kg	1 kg	1.29 kg	1.56 kg	1.8 kg	2.0 kg
R454B	0.296	2.5	1.92	2.16	2.7	3.49	4.22	4.86	5.41
		2.8	1.71	1.93	2.41	3.11	3.76	4.34	4.84
		3.0	1.60	1.80	2.25	2.91	3.51	4.05	4.50

Refrigerant	LFL (lb/ft ³)	h ₀ (ft)	Minimum Room Area (ft ²)						
			0.71 kg	0.8 kg	1 kg	1.29 kg	1.56 kg	1.8 kg	2.0 kg
R454B	0.0185	8.2	20.7	23.3	29.1	37.6	45.4	82.3	58.2
		9.2	18.4	20.8	25.9	33.5	40.5	46.7	52.0
		9.8	17.2	19.4	24.2	31.3	37.8	43.6	48.4

- The total refrigerant charge should be calculated by adding the precharge amount and additional amount.

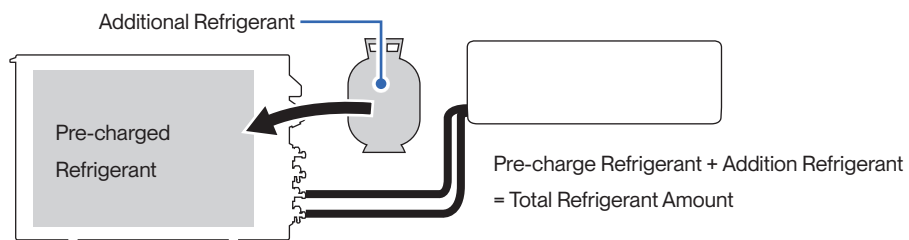

Warning and Safety

Additional Information About R454B Refrigerant











A2L



- When Installing or using the appliance with A2L type refrigerant, beware of the following symbols.
 - This symbol means this appliance uses a flammable refrigerant. If the refrigerant is leaked and exposed to an external ignition source, there is a risk of fire.
 - This symbol means that read the operation instruction carefully.
 - This symbol means that personnel handling the equipment should reference to the installation manual.
 - This symbol means information is available in the installation or operation instruction manual.
- Prior to any work on systems containing flammable refrigerants, always check the area to ensure that the risk of ignition is minimized. All possible ignition sources, such as cigarette, should be kept sufficiently far away from the site of installation, repairing, removing, and disposal during which refrigerant can possibly be released to the surrounding space. Prior to work taking place, the area around the equipment should be surveyed to make sure that there are no flammable hazards or ignition risk. "No smoking" sign shall be displayed.
- Installation or maintenance of refrigerant system shall be taken under a controlled procedure to minimize the risk of flammable gas or vapor being present while the work is being performed.
- All working personnel and others around the working area shall be instructed on the nature of work being carried out. Work in confined spaces shall be avoided. The area around the workspace shall be sectioned off, and ensure that the conditions within the area have been made safe.
- The area shall be checked with an appropriate refrigerant detector prior to and during work to ensure the technician is aware of potentially flammable atmospheres.
- If any hot work is to be conducted on the refrigeration equipment or any associated parts, appropriate fire extinguishing equipment shall be available to hand.
- Ensure that the area is in the open or it is adequately ventilated before breaking into the system or conducting any work that will product heat. A degree of ventilation shall continue during the period that the work is carried out.
- The following checks shall be applied to installations using flammable refrigerants:
 - The refrigerant charge amount is in accordance with the room size within which the refrigerant containing parts are installed.
 - The ventilation machinery and outlet are operating adequately and are not obstructed.
 - If an indirect refrigerating circuit is being used, the secondary circuit shall be check for the presence of refrigerant.
 - Refrigerant pipe or components are installed in a position where they are unlikely to be exposed to any substance which may corrode refrigerant containing components, unless the components are constructed of materials which are inherently resistant to being corroded or are suitable protected against being corroded.
- Detection of flammable refrigerants:
 - Under no circumstances shall potential sources of ignition be used in the searching for or detection of refrigerant leaks. A halide torch or any other detector using naked flame shall not be used.
 - Electronic leak detectors shall be used to detect flammable refrigerant. Ensure that the detector is not a potential source of ignition and is suitable for the refrigerant used.
 - Leak detection equipment shall be calibrated to the refrigerant employed and the appropriate percentage of gas (25% maximum) is confirmed.
 - Leak detection fluids are suitable for use with most refrigerants, but the use of detergents containing chlorine shall be avoided as chlorine may react with the refrigerant and corrode the pipe work.
 - If a leak is suspected, all open flame shall be removed or extinguished.
 - If a leakage of refrigerant found which requires brazing, all of the refrigerant shall be recovered from the system, or isolated (by means of shut off valves) in a part of the system remote from the leak.
 - Oxygen free nitrogen shall be purged through the system both before and during the brazing process.

Warning and Safety

About Installation	
 WARNING 	<ul style="list-style-type: none"> Do not install or store this appliance in a room with continuously operating ignition sources such as open flames, gas appliances, or electric heater. Do not install the appliance within 20" / 50cm of flammable substances such as alcohol, etc. Or pressurized containers such as spray cans. Do not alter, change, or modify the appliance. Do not reuse existing refrigerant line sets when replacing or upgrading an air conditioning system that uses a different refrigerant type. Different refrigerants may have different chemical properties, lubricants and operate in different pressures, do not assume the existing line set to be compatible.
 WARNING 	<ul style="list-style-type: none"> The room for the installation, use, repair, and / or storage of this air conditioner should be greater than 54 sq ft / 5m². Stop valve cover must be installed on the air conditioner to prevent possible refrigerant leak. Refrigerant leakage or damaged pipelines must be inspected and repaired by a qualified HVAC technician. The installation of refrigerant pipe work shall be kept to a minimum length. The appliance must be installed in accordance with applicable federal, state, and local regulations. When evacuating mini-split system with A2L rated refrigerant, an A2L rated vacuum pump must be used. If an A2L rated pump is not available, vacuuming must be done outdoor only. Failure to follow this instruction may result in fire or explosion hazard.
 CAUTION	<ul style="list-style-type: none"> Before installation, make sure the AC system is placed on a flat and stable platform in its upright position for at least 6 hours to prevent lubricating oil from damaging the compressor. Prevent children from accessing the work area during installation to prevent unforeseeable accident. The base of the outdoor unit must be firmly fixed. Carry out a test run after the installation. Installation of a mini split AC requires specialized training and equipment. Hire a licensed professional if not familiar with electrical wiring and HVAC system. The packaging materials are recyclable and should be disposed of in a separate waste bins. The appliance should not be installed in a location where the air outlet of the indoor or outdoor unit is obstructed. Obstruction of these opening may cause damage or malfunctions to the appliance.
About Power and Electricity	
 WARNING 	<ul style="list-style-type: none"> Ensure that the power voltage corresponds to that stamped on the rating plate. A fuse or overload protection device with a suitable capacity for indoor unit must be installed. The appliance must be fitted with means for disconnection from the main power supply under over-voltage category III conditions. All electrical wiring must follow federal, state, or local regulations. When working on the electric terminals, ensure the appliance is disconnected from the power supply. Make sure the appliance is properly grounded to prevent electric shock.
 WARNING 	<ul style="list-style-type: none"> Do not bend, tug, or compress the power cord during installation to prevent damaging the power cord. Damaged electrical cord should be replaced by a qualified electrician. Do not use power extensions and / or multi-socket modules for appliance installation.

Product Specification (Indoor Unit - TPH Series)

	048-TPH-6K2V-C-IN	048-TPH-9K2V-C-IN	048-TPH-12K2V-C-IN	048-TPH-18K2V-C-IN
Power Supply	208 V - 230 V / 60 Hz / 1P	208 V - 230 V / 60 Hz / 1P	208 V - 230 V / 60 Hz / 1P	208 V - 230 V / 60 Hz / 1P
Rated Cooling Capacity (Btu / h)	6000	9000	12000	18000
Rated Heating Capacity (Btu / h)	6000	9000	12000	18000
Noise Level	30 - 43 dBA	26 - 42 dBA	30 - 46 dBA	34 - 48 dBA
Dimension	32.28" x 12.05" x 7.68" 820 mm x 306 mm x 195 mm	32.28" x 12.05" x 7.68" 820 mm x 306 mm x 195 mm	36.22" x 12.05" x 7.68" 920 mm x 306 mm x 195 mm	43.18" x 13.07" x 8.74" 1097 mm x 332 mm x 222 mm
Net Weight	20.7 lb / 9.4 kg	20.7 lb / 9.4 kg	23.1 lb / 10.5 kg	30.9 lb / 14 kg
Suitable Area	Up to 300 sq. ft	Up to 400 sq. ft	Up to 550 sq. ft	Up to 1000 sq. ft
Moisture Removal (per hour)	2.3 pints / 1.1 L	2.3 pints / 1.1 L	4.0 pints / 1.9 L	5.7 pints / 2.7 L

	048-TPH-24K2V-C-IN
Power Supply	208 V - 230 V / 60 Hz / 1P
Rated Cooling Capacity (Btu / h)	24000
Rated Heating Capacity (Btu / h)	24000
Noise Level	32 - 49 dBA
Dimension	43.18" x 13.07" x 8.74" 1097 mm x 332 mm x 222 mm
Net Weight	30.9 lb / 14 kg
Suitable Area	Up to 1500 sq. ft
Moisture Removal (per hour)	7.2 pints / 3.4 L

Product Specification (Outdoor Unit)

	048-TPH-MODU-ID3	048-TPH-MODU-ID4	048-TPH-MODU-ID5	048-TPH-MODU-ID6
Power Supply	208 V - 230 V / 60 Hz / 1P	208 V - 230 V / 60 Hz / 1P	208 V - 230 V / 60 Hz / 1P	208 V - 230 V / 60 Hz / 1P
Rated Cooling Capacity (Btu / h)	20000	27000	36000	48000
Rated Heating Capacity (Btu / h)	20000	27000	36000	48000
Cooling	Power Consumption	1359 W	1928 W	2647 W
	Rated Current	6.0 A	8.9 A	11.5 A
Heating	Power Consumption	1395 W	1907 W	4430 W
	Rated Current	6.2 A	8.6 A	19.8 A
Noise Level	62 dBA	65 dBA	65 dBA	69 dBA
Dimension	38.50" x 16.57" x 31.61" 978 mm x 421 mm x 803 mm	42.28" x 18.43" x 33.58" 1074 mm x 468 mm x 853 mm	42.28" x 18.43" x 33.58" 1074 mm x 468 mm x 853 mm	40.71" x 16.10" x 52.68" 1034 mm x 409 mm x 1338 mm
Net Weight	119 lb / 54 kg	145.5 lb / 66 kg	174.2 lb / 79 kg	249.1 lb / 113 kg
Refrigerant	R454B	R454B	R454B	R454B
Number of Indoor Unit Connection	3	4	5	6

Product Specification (Compatible Indoor Unit)

	048-TPH-MODU-ID3	048-TPH-MODU-ID4	048-TPH-MODU-ID5	048-TPH-MODU-ID6
048-TPH-6K2V-C-IN	O	O	O	O
048-TPH-9K2V-C-IN	O	O	O	O
048-TPH-12K2V-C-IN	O	O	O	O
048-TPH-18K2V-C-IN	O	O	O	O
048-TPH-24K2V-C-IN	X	O	O	O

NOTE: The total Btu for all connected indoor units must stay within 130% of the outdoor unit's Btu. System performance decreases if all indoor units are on simultaneously and exceed outdoor unit's Btu capacity.

Installation Info (Power Supply, Breaker Size)

Power Supply and Breaker Size

	048-TPH-MODU-ID3	048-TPH-MODU-ID4	048-TPH-MODU-ID5	048-TPH-MODU-ID6
Power Supply	208 V - 230 V / 60 Hz / 1P	208 V - 230 V / 60 Hz / 1P	208 V - 230 V / 60 Hz / 1P	208 V - 230 V / 60 Hz / 1P
Cooling	Power Consumption	1359 W	1928 W	2647 W
	Rated Current	6.0 A	8.9 A	11.5 A
Heating	Power Consumption	1395 W	1907 W	1907 W
	Rated Current	6.2 A	8.6 A	11.6 A
Min. Circuit Ampacity		18 A	22 A	28 A
Min. Wire Size (American Wire Gauge)		12 AWG	10 AWG	10 AWG
Breaker Size		30 A	35 A	45 A
				60 A

Installation Info (Refrigerant & Pipe Set)

Indoor Unit Refrigerant Pipe Size

		048-TPH series	
6K	Liquid Line	1/4"	
	Gas Line	3/8"	
9K	Liquid Line	1/4"	
	Gas Line	3/8"	
12K	Liquid Line	1/4"	
	Gas Line	3/8"	
18K	Liquid Line	1/4"	
	Gas Line	1/2"	
24K	Liquid Line	1/4"	
	Gas Line	5/8"	

NOTE: 3/8" to 1/2" Lineset converter and 3/8" to 5/8" Lineset converter should be used with indoor unit that equipped with 1/2" or 5/8" gas line.

Installation Info (Refrigerant & Pipe Line Set)

Refrigerant and Pipe Set Info

	048-TPH-MODU-ID3	048-TPH-MODU-ID4	048-TPH-MODU-ID5	048-TPH-MODU-ID6
Standard Length	16.4 ft / 5 m	16.4 ft / 5 m	16.4 ft / 5 m	16.4 ft / 5 m
Max. Distance Between Indoor and Outdoor Unit	98 ft / 30 m	98 ft / 30 m	98 ft / 30 m	98 ft / 30 m
Max. Elevation Between Indoor and Outdoor Unit	49 ft / 15 m	49 ft / 15 m	49 ft / 15 m	49 ft / 15 m
Max. Total Lineset Length	197 ft / 60 m	262 ft / 80 m	328 ft / 100 m	394 ft / 120 m
Type of Refrigerant	R454B	R454B	R454B	R454B
Factory Refrigerant Pre-charge for up to 25 ft pipe	77.6 oz / 2200 g	98.8 oz / 2800 g	119.9 oz / 3400 g	148.1 oz / 4200 g
Additional Refrigerant Charge	0.11 oz / ft (10 g / m)	0.11 oz / ft (10 g / m)	0.11 oz / ft (10 g / m)	0.11 oz / ft (10 g / m)
Pipe Diameter	1/4"	1/4"	1/4"	1/4"
Torque Parameter	18 - 20 N-M / 13.3 - 14.8 lbf-ft / 1.8 - 2.0 kgf-m	18 - 20 N-M / 13.3 - 14.8 lbf-ft / 1.8 - 2.0 kgf-m	18 - 20 N-M / 13.3 - 14.8 lbf-ft / 1.8 - 2.0 kgf-m	18 - 20 N-M / 13.3 - 14.8 lbf-ft / 1.8 - 2.0 kgf-m
Pipe Diameter	3/8"	3/8"	3/8"	3/8"
Torque Parameter	30 - 35 N-M / 22.1 - 25.8 lbf-ft / 3.0 - 3.6 kgf-m	30 - 35 N-M / 22.1 - 25.8 lbf-ft / 3.0 - 3.6 kgf-m	30 - 35 N-M / 22.1 - 25.8 lbf-ft / 3.0 - 3.6 kgf-m	30 - 35 N-M / 22.1 - 25.8 lbf-ft / 3.0 - 3.6 kgf-m
For Pipe Diameter	1/2"	1/2"	1/2"	1/2"
Torque Parameter	45 - 50 N-M / 33.2 - 36.9 lbf-ft / 4.6 - 5.1 kgf-m	45 - 50 N-M / 33.2 - 36.9 lbf-ft / 4.6 - 5.1 kgf-m	45 - 50 N-M / 33.2 - 36.9 lbf-ft / 4.6 - 5.1 kgf-m	45 - 50 N-M / 33.2 - 36.9 lbf-ft / 4.6 - 5.1 kgf-m
For Pipe Diameter	—	5/8"	5/8"	5/8"
Torque Parameter	—	60 - 65 N-M / 44.3 - 48.0 lbf-ft / 6.6 - 6.6 kgf-m	60 - 65 N-M / 44.3 - 48.0 lbf-ft / 6.6 - 6.6 kgf-m	60 - 65 N-M / 44.3 - 48.0 lbf-ft / 6.6 - 6.6 kgf-m

NOTE: ¹ 3/8" to 1/2" Lineset converter and 3/8" to 5/8" Lineset converter should only be used with indoor unit that equipped with 1/2" or 5/8" gas line.

Installation Info

Picking a Installation Location for the Indoor Unit (Wall Type)

- Ensure the installation complies with the minimum clearance space surrounding the unit and is within the maximum piping length and maximum elevation defined in the installation information.

Page 14

- Make sure the wall is strong enough to hold the weight of the indoor unit and prevent it from vibration.
- Make sure the air inlet and outlet are clear of any obstruction.
- Make sure condensation can be easily drained.
- A place where all connections can be easily made to the outdoor unit.
- A place where the indoor unit is out of children's reach.
- A place where the indoor unit is accessible for maintenance.
- Install the indoor unit 10 ft / 3 m away from TV or radio appliances.

NOTE: Radio interference may occur if appliances are placed too close to each other.

- Do not install in a laundry room or by a swimming pool.
- There should not be any heat source near the indoor unit.
- Do not install the indoor unit near the door way.

 To prevent the indoor unit from falling down and blocking exit way in case of an emergency such as fire or earthquake etc.

Picking a Installation Location for the Outdoor Unit

- Do not install the outdoor unit near a heat source, steam, or flammable gas.
- Do not install the outdoor unit in windy or dusty locations.
- Do not install the outdoor unit in places where people often pass.
- Avoid installing the outdoor unit in places where it will be exposed to direct sunlight.

NOTE: If necessary, build a protection that does not interfere with the airflow.

- Make sure there is enough space around the outdoor unit to circulate air.

Page 21

- Outdoor unit must be placed in a safe and solid location.
- The outdoor unit should ideally be placed on a elevated concrete pad.
- If installing in snowy region, it is recommended the outdoor unit to be installed above the seasonal snow level.



- Before installation, make sure the AC system is placed on a flat and stable platform in its upright position for at least 6 hours to prevent lubricating oil from damaging the compressor.



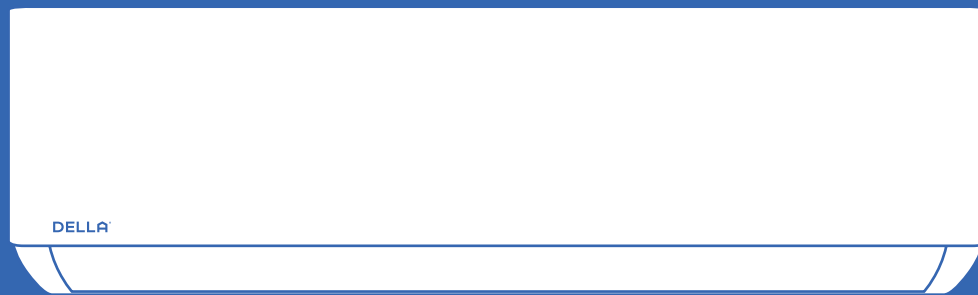

Wall Mounted Type Indoor Unit

Installation Guide

Name of Parts

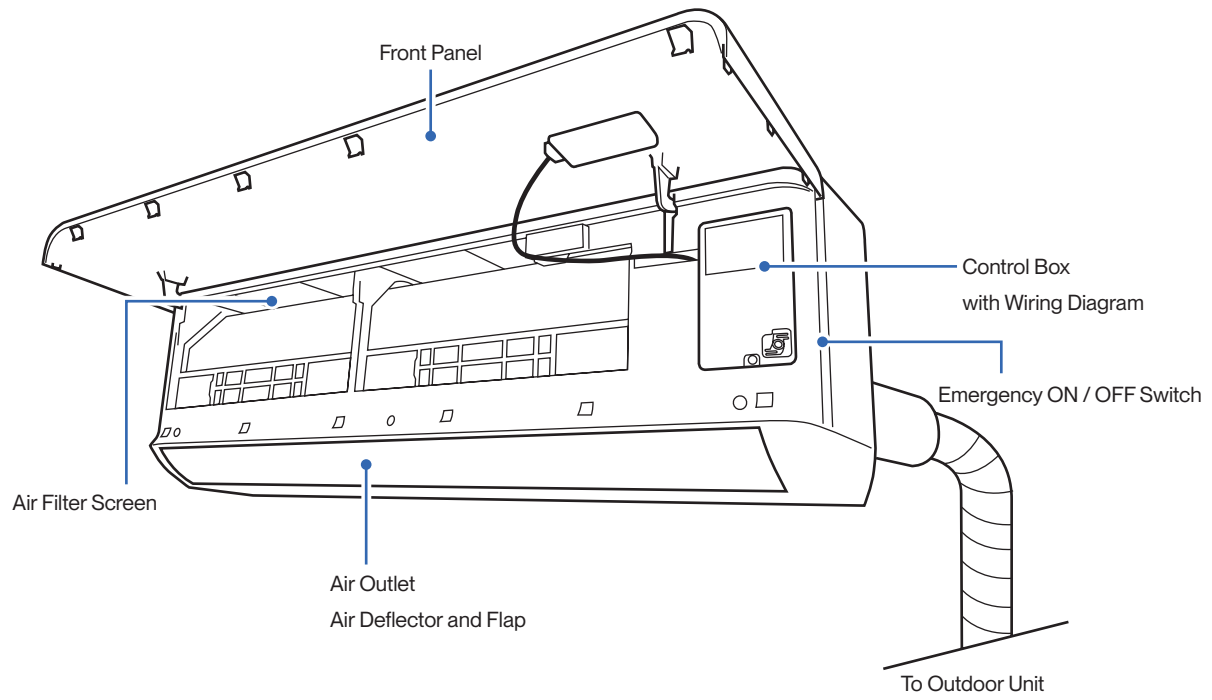

Name of Parts

Included Accessories (for each wall mount indoor unit)

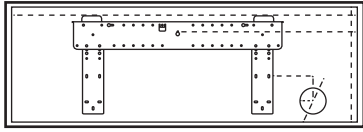

Bracket Template
1x

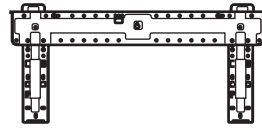

Mounting Plate
1x



Communication Cable
1x

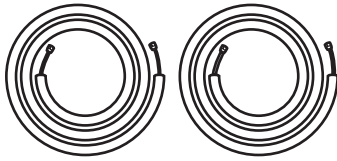

Refrigerant Pipe
Narrow 1x
Thick 1x

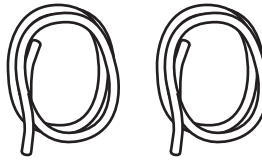

Drain Hose
2x

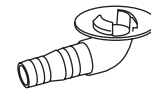

Drainage Joint
1x

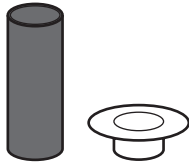

Wall Sleeve & Cover
1x

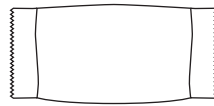

Plastic Putty
1x

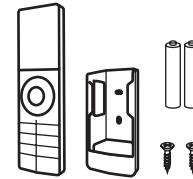

Remote Control, Holder 1x
Battery 2x

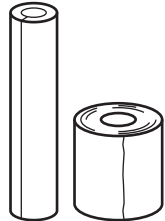

Insulation Foam & Wrap
1x



Rubber Foot Pad
4x



1/2" Male to 3/8" Female
Lineset Converter ¹



5/8" Male to 3/8" Female
Lineset Converter ²

NOTE: ¹ Lineset converter is supplied with the outdoor unit for indoor unit models that uses a 1/2" or 5/8" refrigerant pipe.

Name of Parts

Tools Needed for Wall Mounted Indoor Unit (Not included)

- Screw Driver
- Hole Saw Ø2.75" / Ø70mm
- Refrigerant Leak Detector / Liquid Leak Detector
- Allen Wrench
- Spanner
- Torque Wrench
- Measuring Tape
- Spirit Level
- Stud Finder
- Thermometer
- Vacuum Pump
- Dry Wall Anchors / Molly Bolts
- Wood Screws
- Floor Mounting Base Kit / Wall Mount Kit
- Power Supply Cable
- Micron Gauge / AC manifold Gauge
- Copper Pipe Bender / Spring Bender
- Caulk
- Tubing Cutter*
- Pipe Reamer*
- Tubing Flaring Tool*
- Wire cutter*

NOTE: Tools marked with * are needed for shortening the refrigerant pipe and / or electrical wire to the exact desired length.

ONLY a qualified HVAC technician should attempt altering the pipe length and / or the wire length.

Installation Preview

- 1 Choose the installation location
[Page 15](#)
- 2 Drill wall hole and
 Install mounting plate
[Page 22-23](#)
- 3 Indoor unit connection
 - Connect the drain hose to the indoor unit
[Page 24](#)
 - Pass the communication cable into the indoor unit
[Page 25](#)
- 4 Mount the indoor unit
[Page 28](#)
- 5 Connect refrigerant pipes to indoor unit
[Page 29](#)

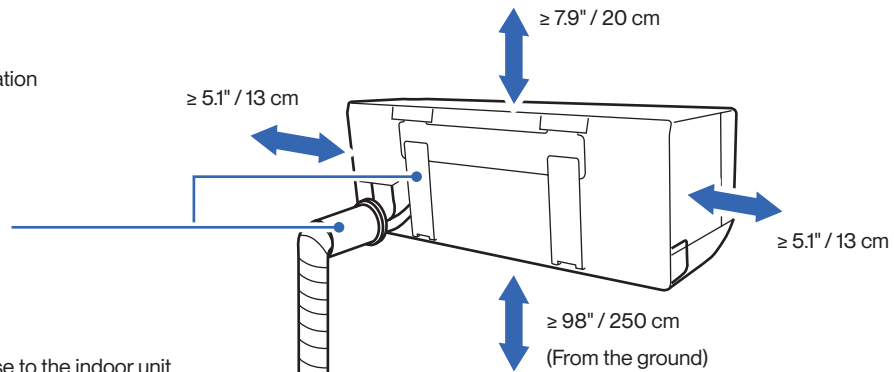

	MODU - 1D3	MODU - 1D4	MODU - 1D5	MODU - 1D6
Standard Length per Indoor Unit	16.4 ft / 5 m			
Max. Distance per Indoor Unit	98 ft / 30 m			
Max. Elevation per Indoor Unit	49 ft / 15 m			

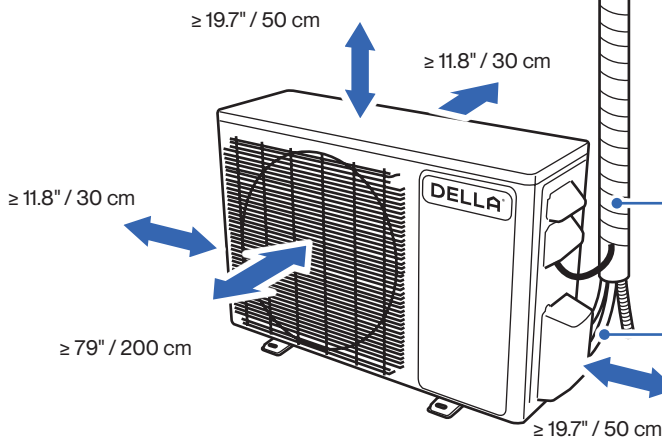

- 6 Placing the outdoor unit
[Page 35-36](#)
- 7 Connection between indoor and outdoor unit
 - Connect the refrigerant pipes
[Page 38, 39](#)
 - Connect the electrical wires
[Page 40](#)
- 8 Vacuum pumping
[Page 46-49](#)
- 9 Finishing
[Page 52](#)
- 10 Check list
[Page 53](#)
- 11 Test run
[Page 54](#)

Indoor Unit Installation

Install the Mounting Bracket

1. Locate the studs and electrical wires inside the wall. Then use the template included with the indoor unit or the etched marking on the mounting plate to determine the exact mounting location.
2. Use a spirit level to level the mounting plate on the wall. Then mark out the screw hole positions.
3. Insert wall anchors into the holes and affix the mounting plate to the wall using screws.
Use a wood screw if the hole position is directly on a wood stud.

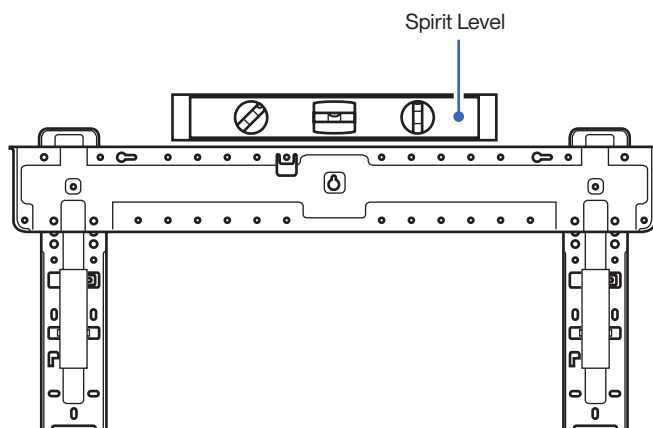
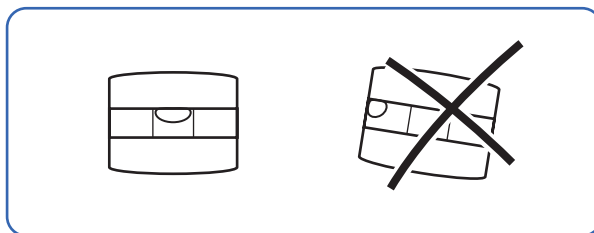

Hollow Drywall

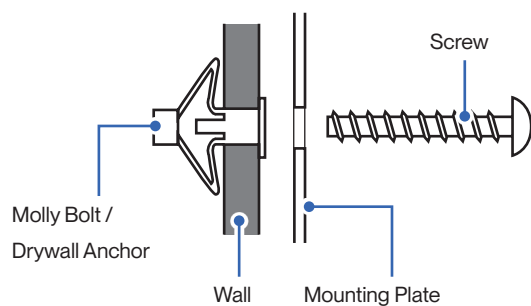

Wood Stud

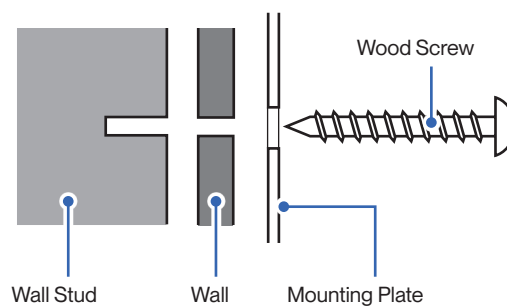

- You must use the correct wall anchor according to the type of the wall.

Indoor Unit Installation

Drill Wall Hole and Insert Wall Sleeve

- Pick 1 of the 3 piping positions on your indoor unit.

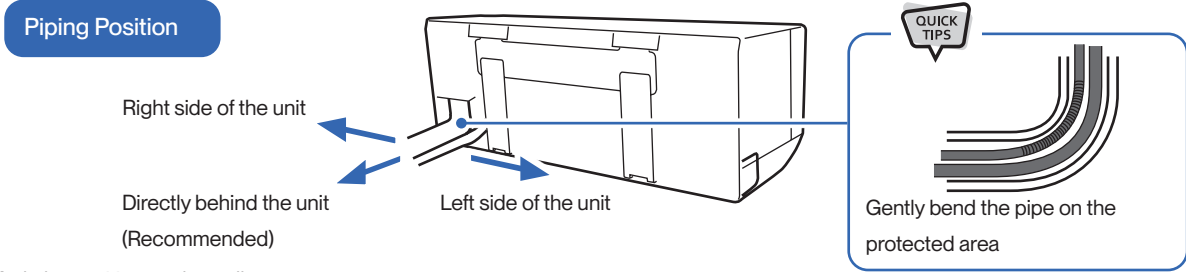

- Mark the position on the wall.

Example of Wall Hole Position with Piping Directly Behind the Indoor Unit

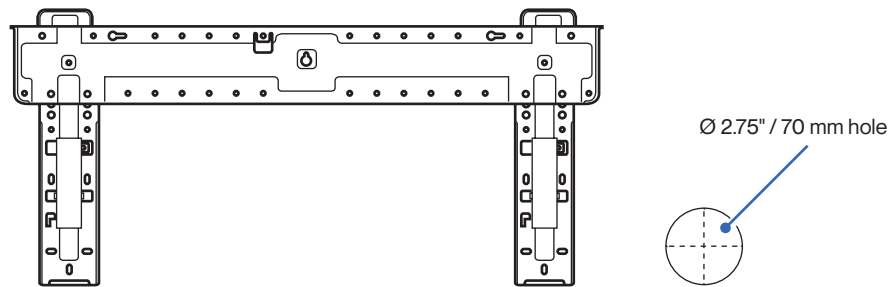

WARNING

- Make sure there is no building structure pillar, stud, electrical wire, or any water pipes in the way of the drill hole. Drilling into electrical wires or water pipes inside the wall may cause electric shock, fire, or water damage.

- Drill a 2.75" / 70 mm hole from the indoor wall to the outdoor wall. The hole must be slanted downward with a small angle.
- Insert the wall sleeve and sleeve cover into the wall. Then seal off gaps with putty or caulk.

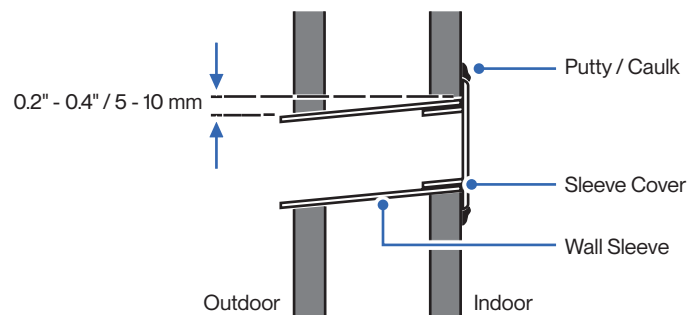

!

- Always insert the sleeve into the wall hole and seal the surrounding with putty / caulk. This will prevent water, insects, or small animals from getting into the house.

Indoor Unit Installation

Connect the Indoor Unit Drain Hose

1. Connect the drainage hose to the indoor unit drainage port.

NOTE: In some models, drainage ports are available on both sides of the indoor unit. You can choose one side to attach the drain hose and insert a rubber plug on the unused port. Always pick the side closer to the wall hole.

2. Make sure the joint is firmly connected and has a good seal.
3. Wrap the joint with Teflon tape to prevent any possible leak.

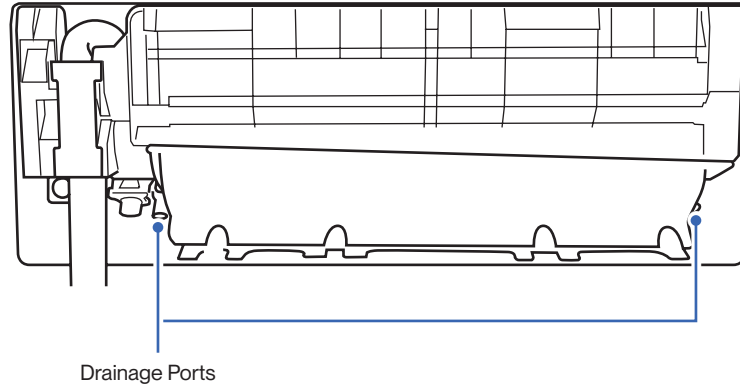

Drain Hose Installation

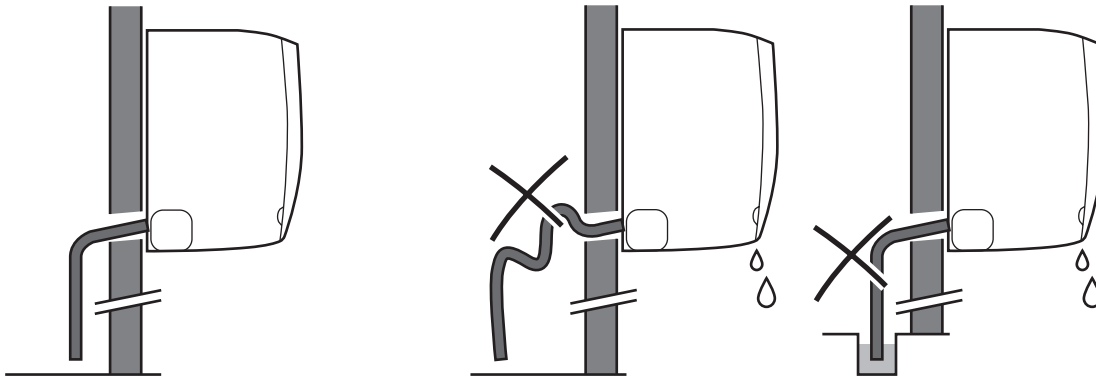

- Drain hose must be slanted downward and leave a small gap between the ground and the hose.



- Avoid having bends or dents on the drain hose.
- Do not leave the end of the hose into drainage gutter.

Indoor Unit Installation

Connect Communication Cable to the Indoor Unit



WARNING

- Electrical wiring must be done by a qualified technician or electrician. Failing to connect the wires correctly will cause short circuit, a fire, and property damage.
- Do not use the communication cable as power supply cable.

1. Open the front panel of the indoor unit.
2. Remove the control box cover from the control box.
3. Pass the communication cable from the back of the indoor unit to the control box.
4. Unscrew the cable clamp in the indoor unit.
5. Connect communication wires to the corresponding terminal and secure the cable using the cable clamp.
6. Reinstall the control box cover and close the indoor unit's front panel.

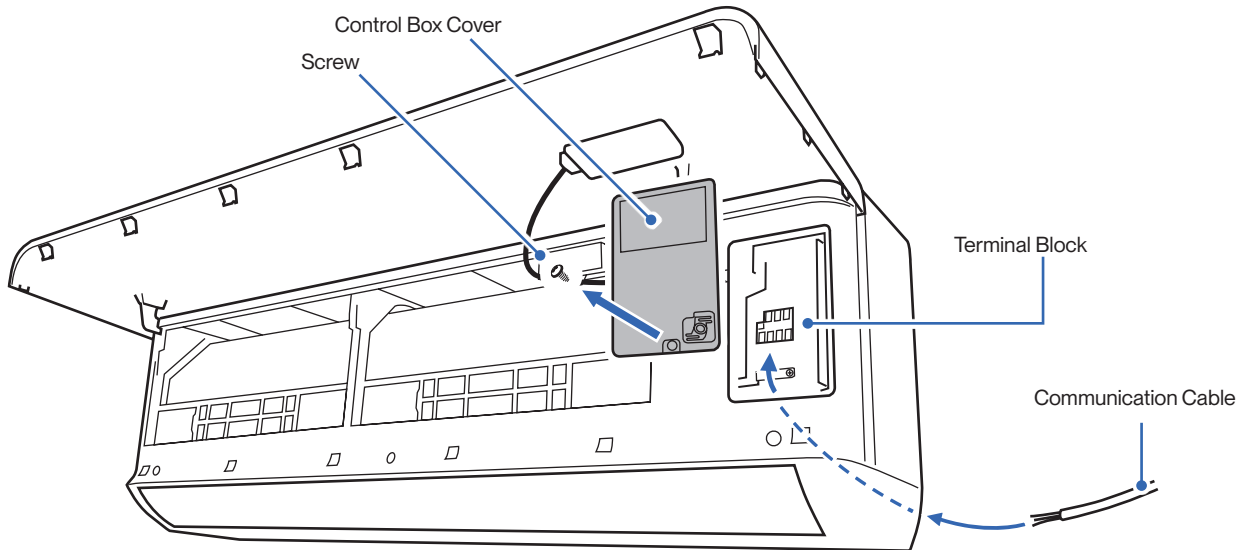

- Purchase communication cable that is 3 - 4 ft longer than your planned refrigerant lineset length.
- Do not modify the communication cable by extending the cable.

Indoor and Outdoor Unit Installation

Indoor Unit Circuit Diagram

048-TPH-6K2V-C-IN
 048-TPH-9K2V-C-IN
 048-TPH-12K2V-C-IN
 048-TPH-18K2V-C-IN
 048-TPH-24K2V-C-IN

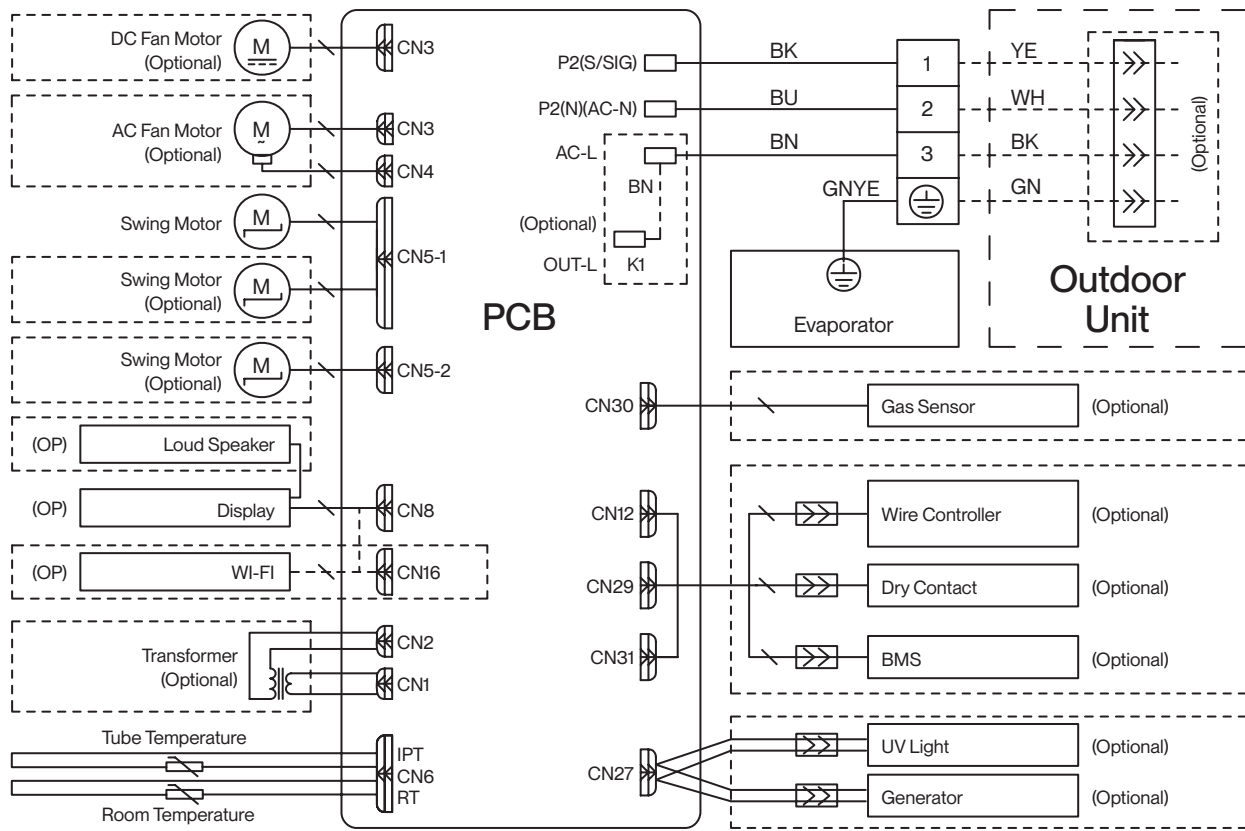

Indoor Unit Installation

Bundle the Indoor Unit Refrigerant Pipes, Hose, and Cable

Refrigerant Pipes, drain hose, and electric cable must be properly arranged and bundled with insulation tape before passing them through the wall hole.

1. Arrange the refrigerant pipes, drain hose, and electric cable according to the image below.
2. Wrap the bundle with insulation pipe.

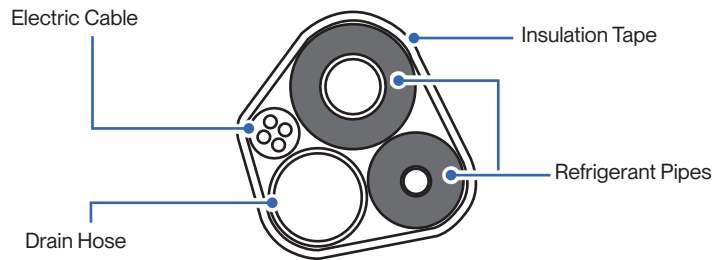

- Drain hose must be positioned at the bottom to prevent water leakage.

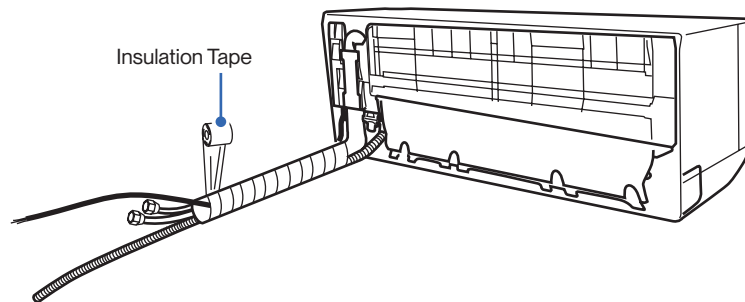

Indoor Unit Installation

Pass Line Set Through Wall Hole and Mount Indoor Unit

1. Carefully pass the line set bundle through the wall hole.
2. Hook the top of the indoor unit on the mounting plate.
Push the unit lightly left and right to make sure it is firmly hooked on the mounting plate.
3. Push down the bottom of the indoor unit and snap into the mounting plate.

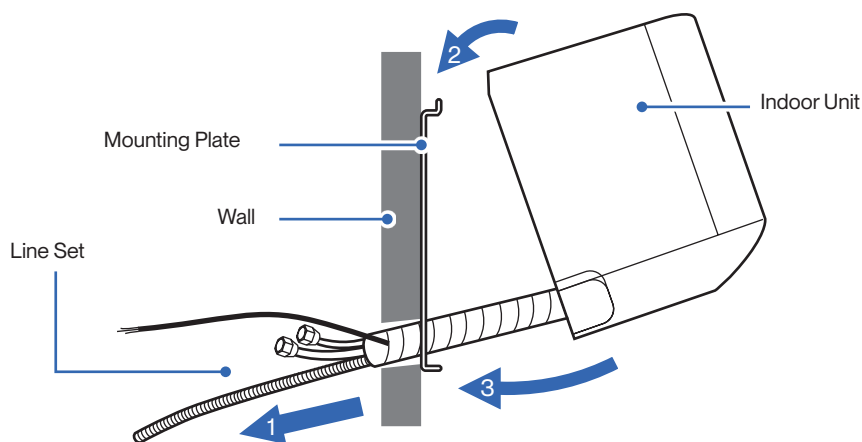

Pass Line Set Through Wall Hole and Mount Indoor Unit (Left Piping Direction)

If you choose to have the piping direction on the left side of the indoor unit,

1. Carefully pass the drain hose and electric cable through the wall hole.
2. Hook the top of the indoor unit on the mounting plate.
Push the unit lightly left and right to make sure it is firmly hooked on the mounting plate.
3. Place a wedge or foam block or something slightly soft between the mounting plate and the indoor unit for a easier installation process in later steps.
4. Push down the bottom of the indoor unit and snap into the mounting plate after connecting the refrigerant pipes to the indoor unit.

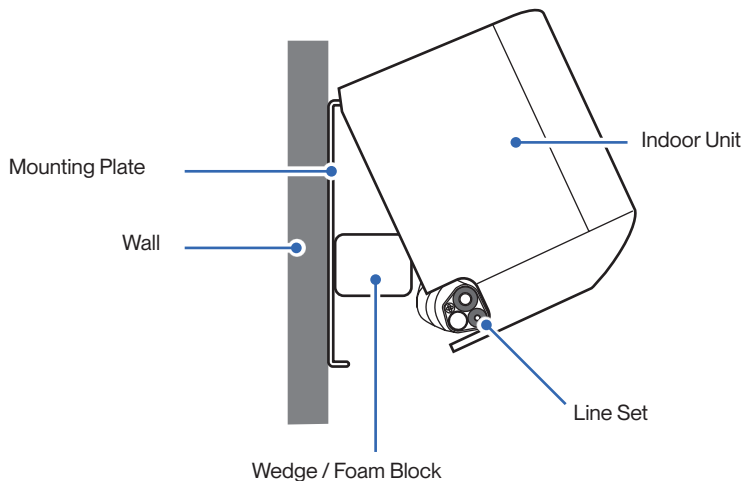

- The indoor unit is not secured in place at this step for left side piping direction installation.
Handle the unit and line set with caution. It is recommended to have a person looking after the unit and make sure it does not fall during the later installation process.

Indoor Unit Installation (Wall Mount Indoor Unit)

Connect the Refrigerant Pipes to the Indoor Unit

1. Align the refrigerant pipes to that from the indoor unit, then tighten the nut by hand.
2. Use a torque wrench to tighten the nut according to the torque requirement.

QUICK TIPS

- A thin layer of nylog can be applied to the inside of the flare to provide better seal. (OPTIONAL)
- Make sure no nylog is on the outside of the flare.

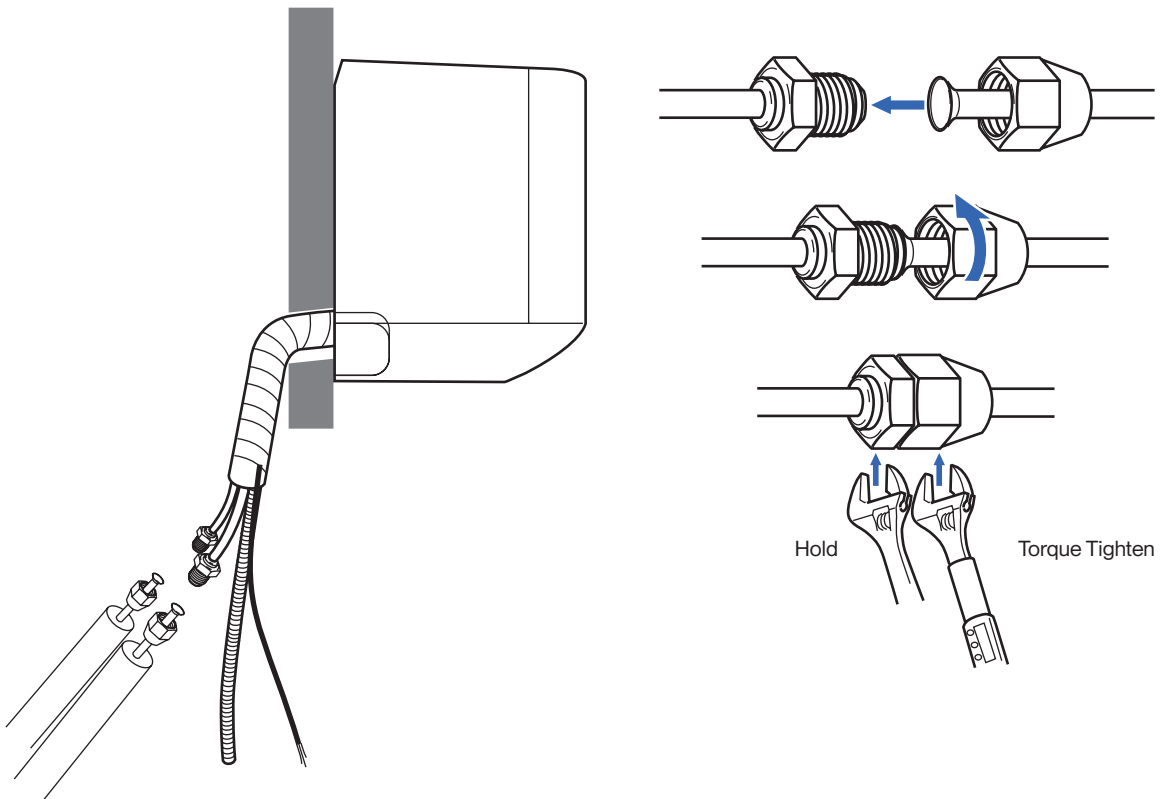

Pipe Diameter	1/4"	3/8"	1/2"	5/8"
Torque Parameter	18 - 20 N-M 13.3 - 14.8 lbf-ft 1.8 - 2.0 kgf-m	30 - 35 N-M 22.1 - 25.8 lbf-ft 3.0 - 3.6 kgf-m	45 - 50 N-M 33.2 - 36.9 lbf-ft 4.6 - 5.1 kgf-m	60 - 65 N-M 44.3 - 48.0 lbf-ft 6.1 - 6.6 kgf-m



- Connection must be torque tighten to prevent leak. Do not over tighten.
- Refrigerant piping and torque requirement for specific model is on [Page 14](#).

Indoor Unit Installation (Wall Mount Indoor Unit)

Preparing the Refrigerant Pipe

1. Unroll the included refrigerant pipe.

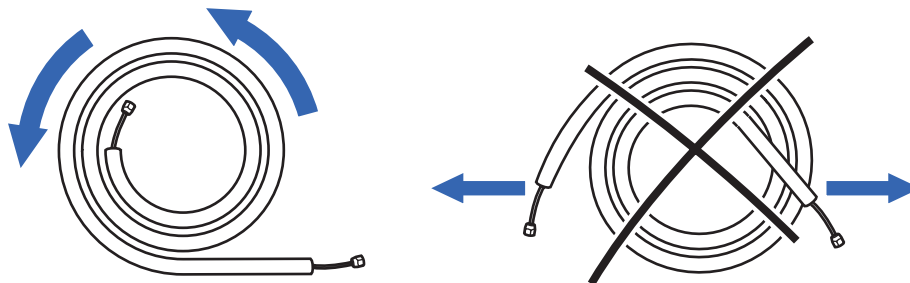

- Do not pull the refrigerant pipe to prevent the pipe from kinking or bending.

2. Remove the cover and make sure the ports are clean and smooth.



Imperfect Flaring



Dirty Flaring

3. In the case of a imperfect flaring or the pipe needs to be shorten for the installation, refrigerant pipe should be cut and flare by qualified technician.



- Use a pipe bender or spring bender to shape the refrigerant pipes along wall and corners. Bending the pipe without bending tools would easily kink or damage the pipe, which would cause refrigerant starvation, or leakage in the system.

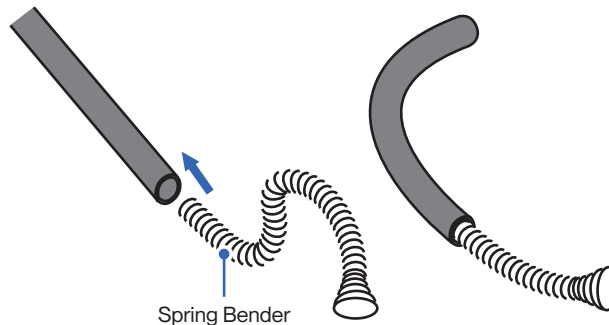
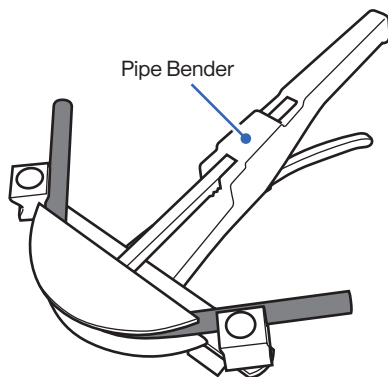

Indoor Unit Installation (Wall Mount Indoor Unit)

Cutting and Flaring Refrigerant Pipe



WARNING

- Any refrigerant pipe alteration should only be done by qualified technician. Incorrect work may cause refrigerant leak, reduce cooling / heating efficiency, damage to the unit. Warranty does not cover any damage(s) caused by incorrect refrigerant pipe alteration.

- Cut the copper pipe with a pipe cutter.
- Remove any burrs or rough edges with a reamer with the pipe facing downward.
NOTE: The opening of the pipe must face toward the ground to prevent chips or dust from entering the pipe.
- Insert the flare nut to the pipe.
- Use the flaring tool to flare the copper pipe. The flaring angle must match to that of the refrigerant lines from the unit.

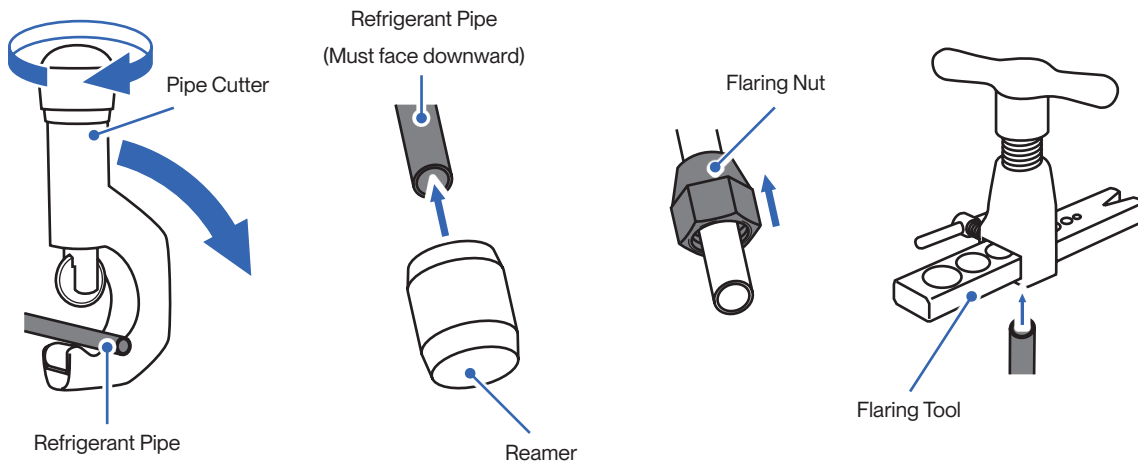



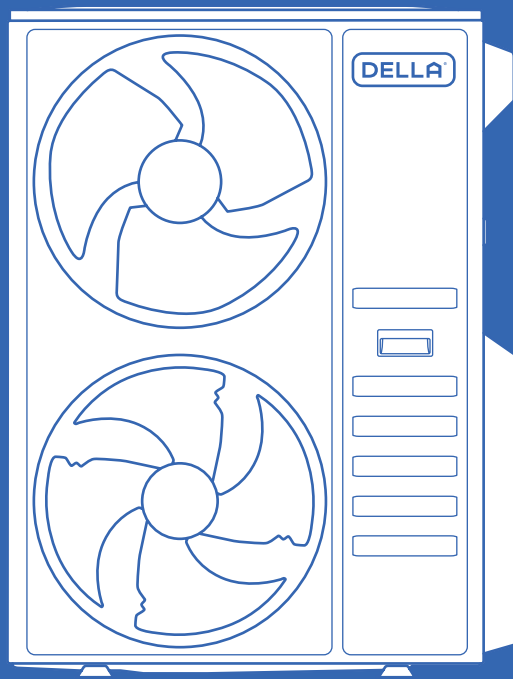

Outdoor Unit

Name of Parts

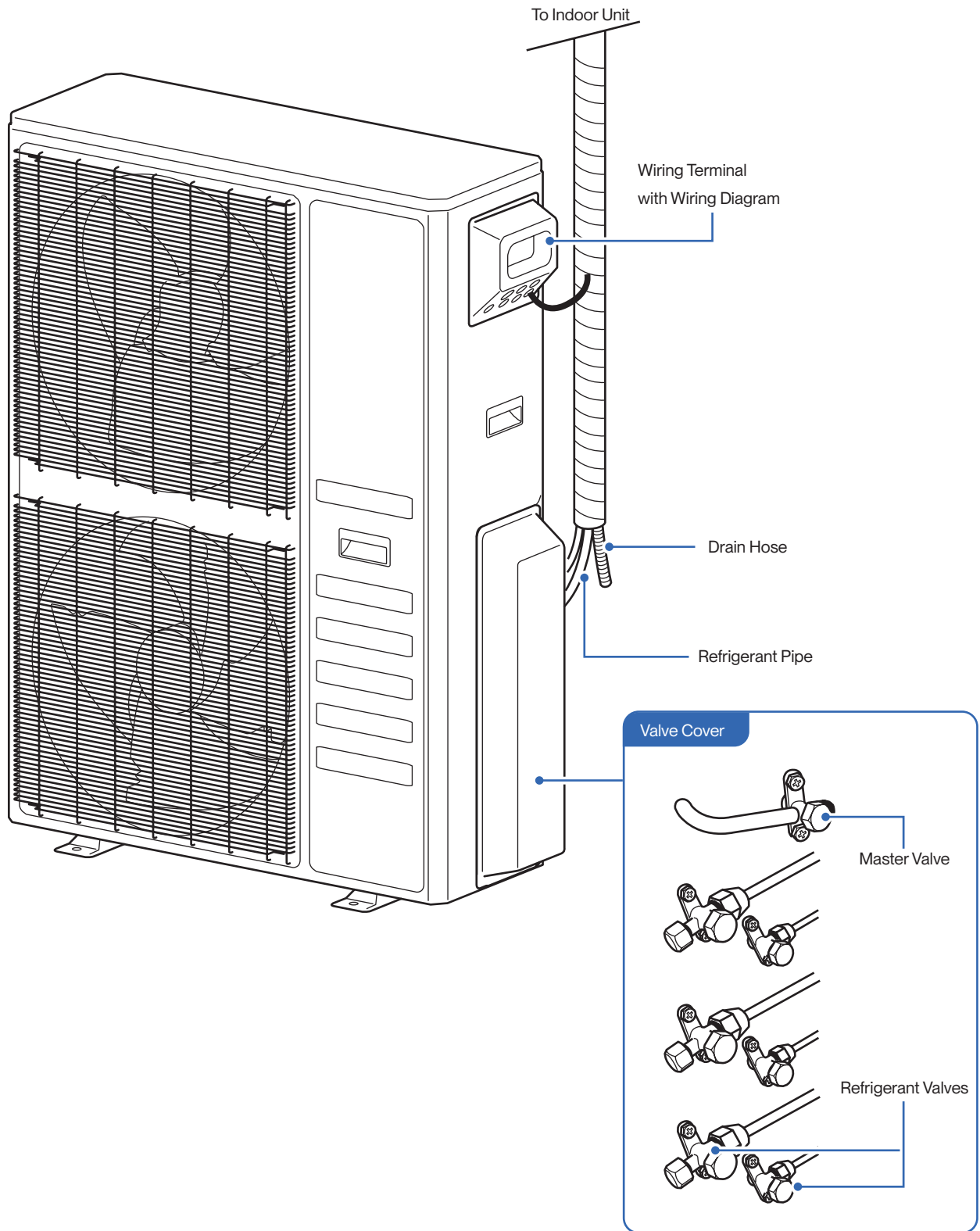

Outdoor Unit Installation

Secure the Outdoor Unit (Ground Installation)

1. Place a concrete pad on the installation location.
NOTE: You do not need a concrete pad if the ground is concrete.
2. Mount the indoor unit on a mounting stand or base kit.
NOTE: Rubber foot pads can be placed between the outdoor unit and the mounting kit to reduce vibration or noise.
3. Drill holes on the concrete pad or concrete ground.
4. Secure the mounting stand or base kit on the concrete with concrete anchor bolts.

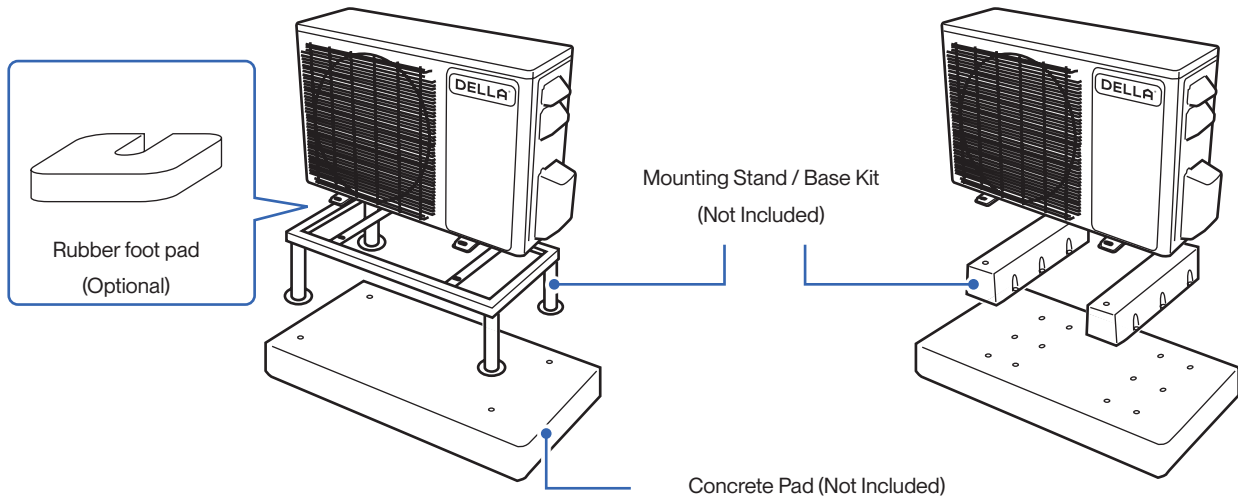

- Outdoor unit should be installed on a elevated mounting stand with snow cover if using in a snowy region.

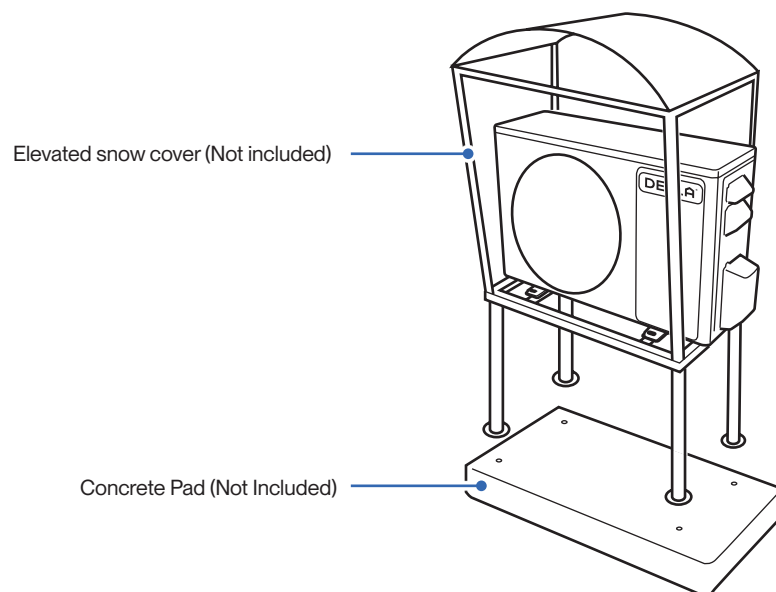

Outdoor Unit Installation

Secure the Outdoor Unit (Wall Installation)

The outdoor unit can be fixed on a wall mounting bracket if there is no ground mounting option.

1. Measure the distance between the outdoor unit's legs.
2. Mount the wall mounting bracket on the wall.
3. Secure the outdoor unit on the wall mounting bracket.

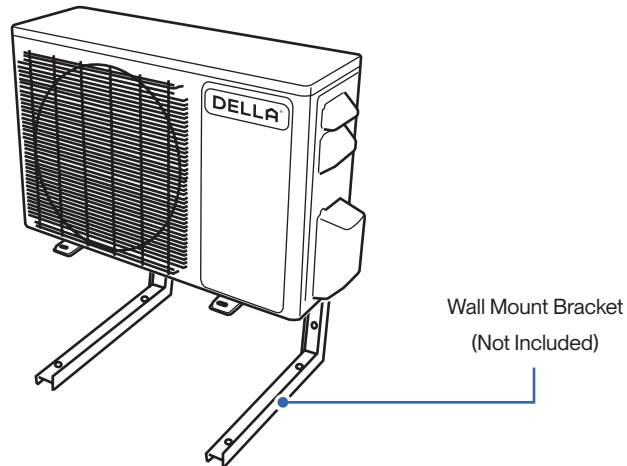

- The wall mounting bracket and the wall must be able to support at least 4 times the weight of the outdoor unit.
- Large multi-zone unit that exceed the weight capacity of the mounting bracket should be installed on concrete ground.

Attach Drainage Port and Hose

Outdoor unit drainage helps prevent condensation or frost inside the unit during cold weather.

1. Drainage joint installation is recommended for heat pump models.
2. Insert drainage joint into the bottom hole of the outdoor unit.
3. Connect one end of the drain hose to the joint and the other end to your desired drainage point.

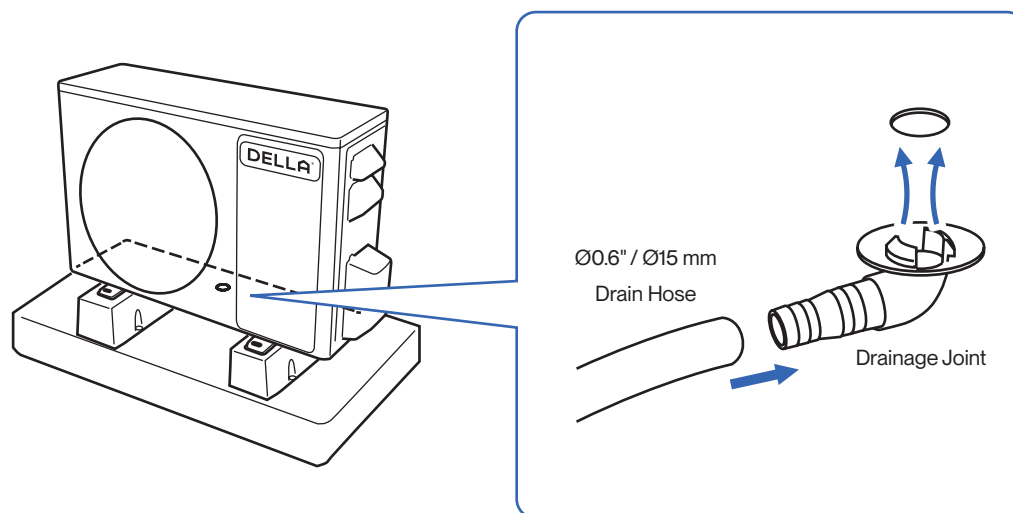

Outdoor Unit Installation

Refrigerant Pipes and Electrical Cables Connection



- Each indoor units on the multi zone system must be connected to their respective corresponding refrigerant valve and electrical terminal.

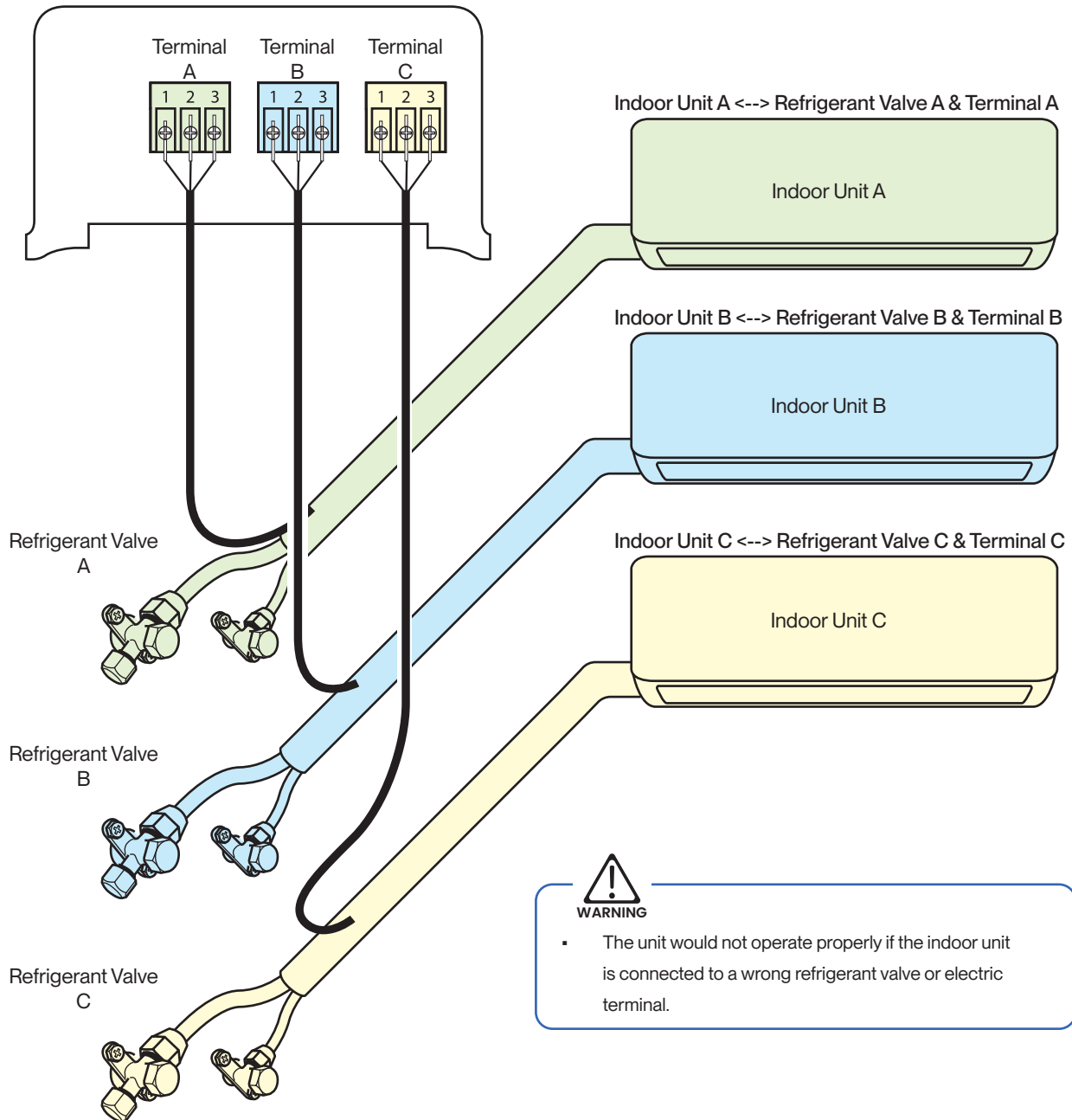

Outdoor Unit Installation

Connect the Refrigerant Pipes to the Outdoor Unit

1. Unscrew the screws on the valve cover, press it down gently and remove the cover from the outdoor unit.
2. Remove plastic caps from the end of the valves.
3. Align the refrigerant pipes to the outdoor unit valve, then tighten the nut by hand.
4. Use a torque wrench to tighten the nut according to the torque requirement.

QUICK TIPS

- A thin layer of nylog can be applied to the inside of the flare to provide better seal. (OPTIONAL)
- Make sure no nylog is on the outside of the flare.

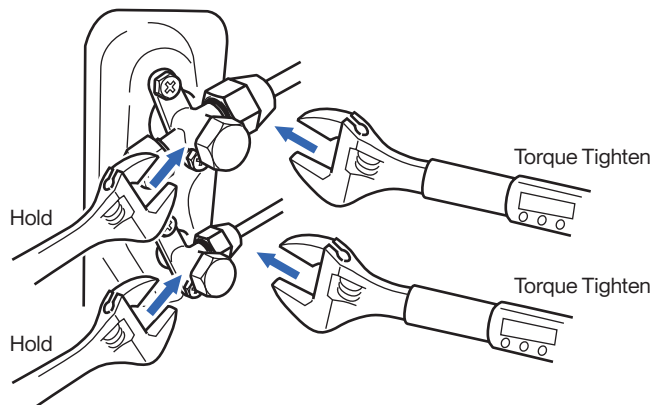
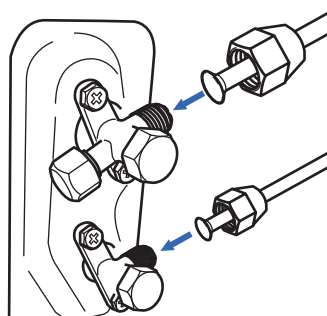
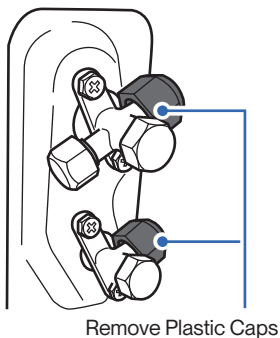
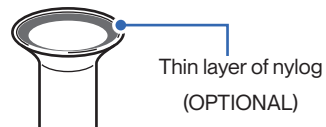

Pipe Diameter	1/4"	3/8"	1/2"	5/8"
Torque Parameter	18 - 20 N-M 13.3 - 14.8 lbf-ft 1.8 - 2.0 kgf-m	30 - 35 N-M 22.1 - 25.8 lbf-ft 3.0 - 3.6 kgf-m	45 - 50 N-M 33.2 - 36.9 lbf-ft 4.6 - 5.1 kgf-m	60 - 65 N-M 44.3 - 48.0 lbf-ft 6.1 - 6.6 kgf-m



- Connection must be torque tighten to prevent leak. Do not over tighten.
- Refrigerant piping and torque requirement for specific model is on [Page 14](#).

Indoor and Outdoor Unit Installation

Connect the Refrigerant Pipes to the Outdoor Unit (Using Lineset Converter)

Some indoor unit models are equipped with a 1/2" or 5/8" copper pipe on the gas line, and require a lineset converter for proper connection to the outdoor unit.

1. Unscrew the screw on the valve cover, press it down gently and remove the cover from the outdoor unit.
2. Remove plastic caps from the end of the valves.

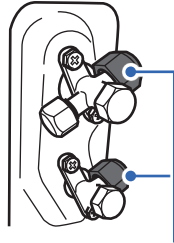

Remove Plastic Caps

3. Align the lineset converter to the outdoor unit valve, then use a torque wrench to tighten the converter according to the torque requirement.

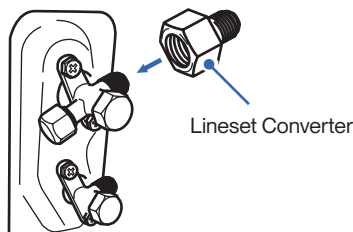

Lineset Converter

Converter Size	3/8"
Torque Parameter	30 - 35 N-M 22.1 - 25.8 lbf-ft 3.0 - 3.6 kgf-m

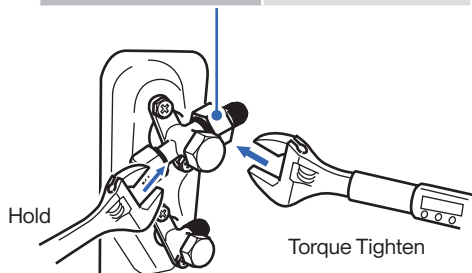

Hold

Torque Tighten

4. Align the liquid line to the outdoor unit valve, and the gas line to the converter, then tighten the nut by hand.

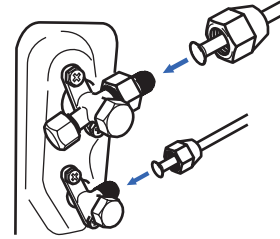

5. Use a torque wrench to tighten the nut according to the torque requirement.

Gas Pipe Diameter	1/2"	5/8"
Torque Parameter	45 - 50 N-M 33.2 - 36.9 lbf-ft 4.6 - 5.1 kgf-m	60 - 65 N-M 44.3 - 48.0 lbf-ft 6.1 - 6.6 kgf-m

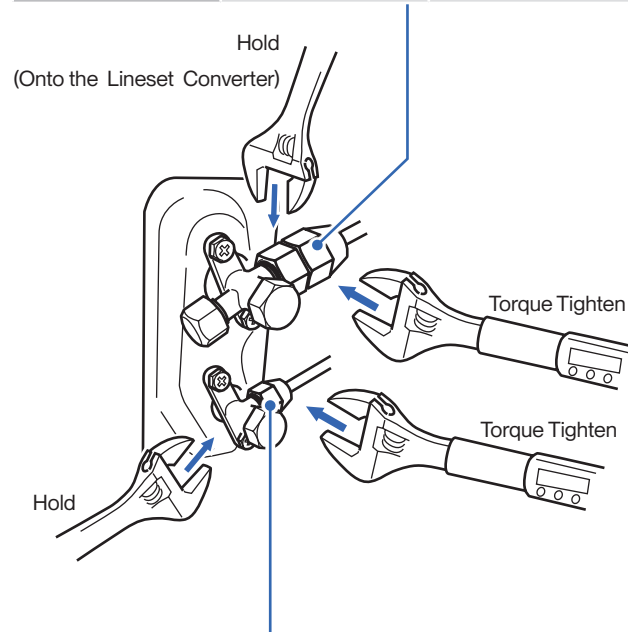

Hold

(Onto the Lineset Converter)

Torque Tighten

Torque Tighten

Hold

Liquid Pipe Diameter	1/4"
Torque Parameter	18 - 20 N-M 13.3 - 14.8 lbf-ft 1.8 - 2.0 kgf-m

Outdoor Unit Installation

Connect the Electrical Wire



WARNING

- Electrical wiring must be done by a qualified technician or electrician. Failing to connect the wires correctly will cause short circuit, a fire, and property damage.
 - Do not use the communication cable as power supply cable.
1. Unscrew the screws from the wiring cover, press the cover downward gently, and remove from the outdoor unit.
 2. Unscrew the cable clamp.
 3. Insert the communication cable from the indoor unit through the opening on the cover, then connect the wires to the outdoor unit terminal.
 4. Insert power supply cable (not included) to the opening on the cover, then connect the wires to the outdoor unit terminal.
 5. Turn off any power from the power supply, and connect the wires to the power supply circuit box.
Exact power supply cable and breaker size requirement on [Page 12](#)
 6. Reinstall the wiring cover to its original place.

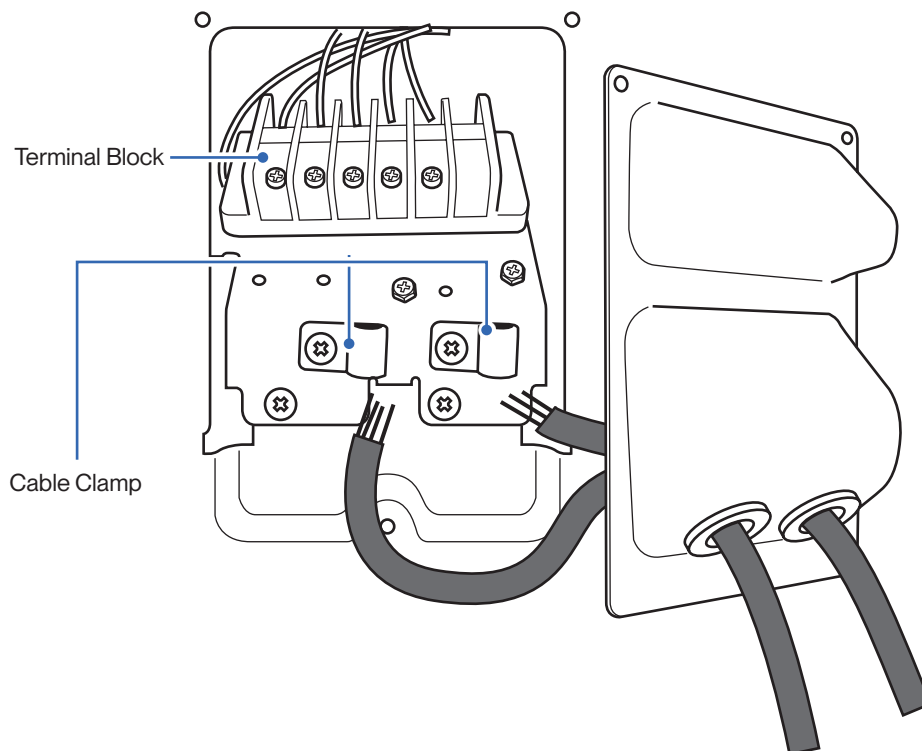

Indoor and Outdoor Unit Installation

Outdoor Unit Circuit Diagram

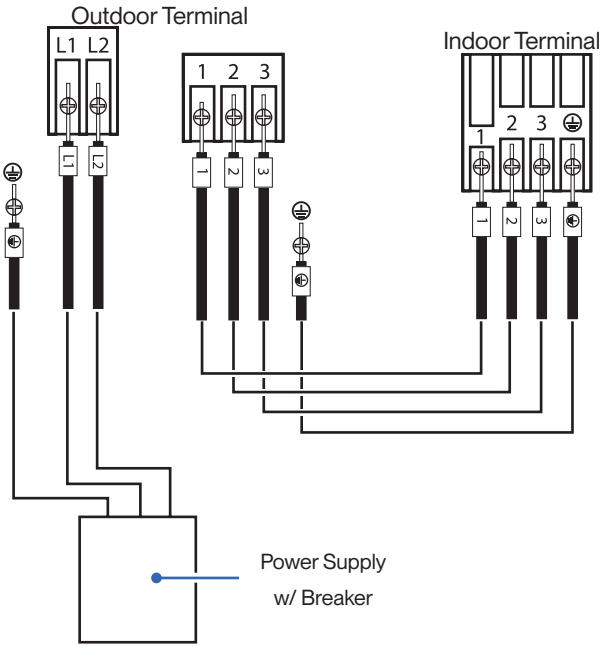

Outdoor Unit Installation

Outdoor Unit Circuit Diagram

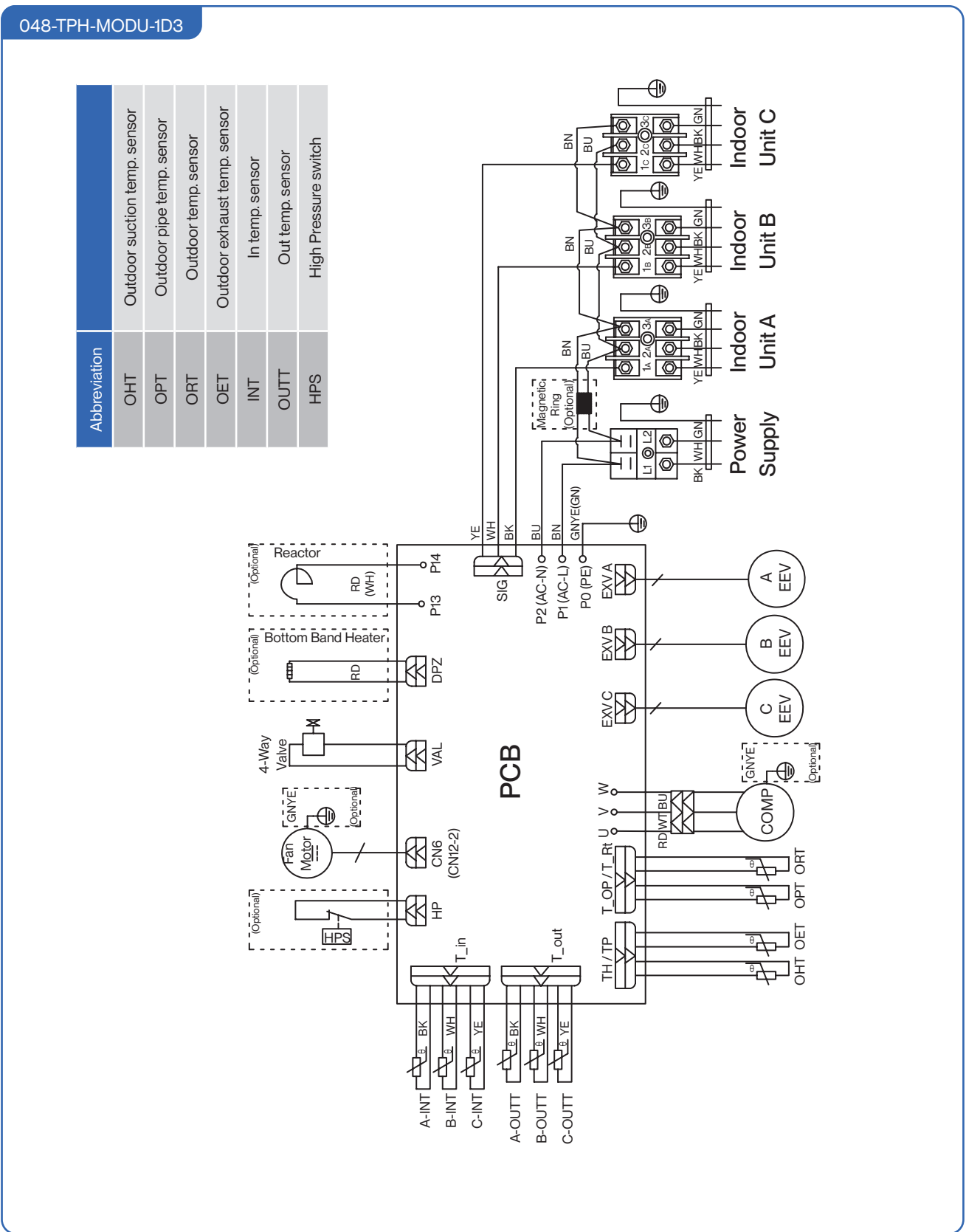

Outdoor Unit Installation

Outdoor Unit Circuit Diagram

048-TPH-MODU-1D4

Abbreviation	Description
OHT	Outdoor suction temp. sensor
OPT	Outdoor pipe temp. sensor
ORT	Outdoor temp. sensor
OET	Outdoor exhaust temp. sensor
INT	In temp. sensor
OUTT	Out temp. sensor
HPS	High Pressure switch

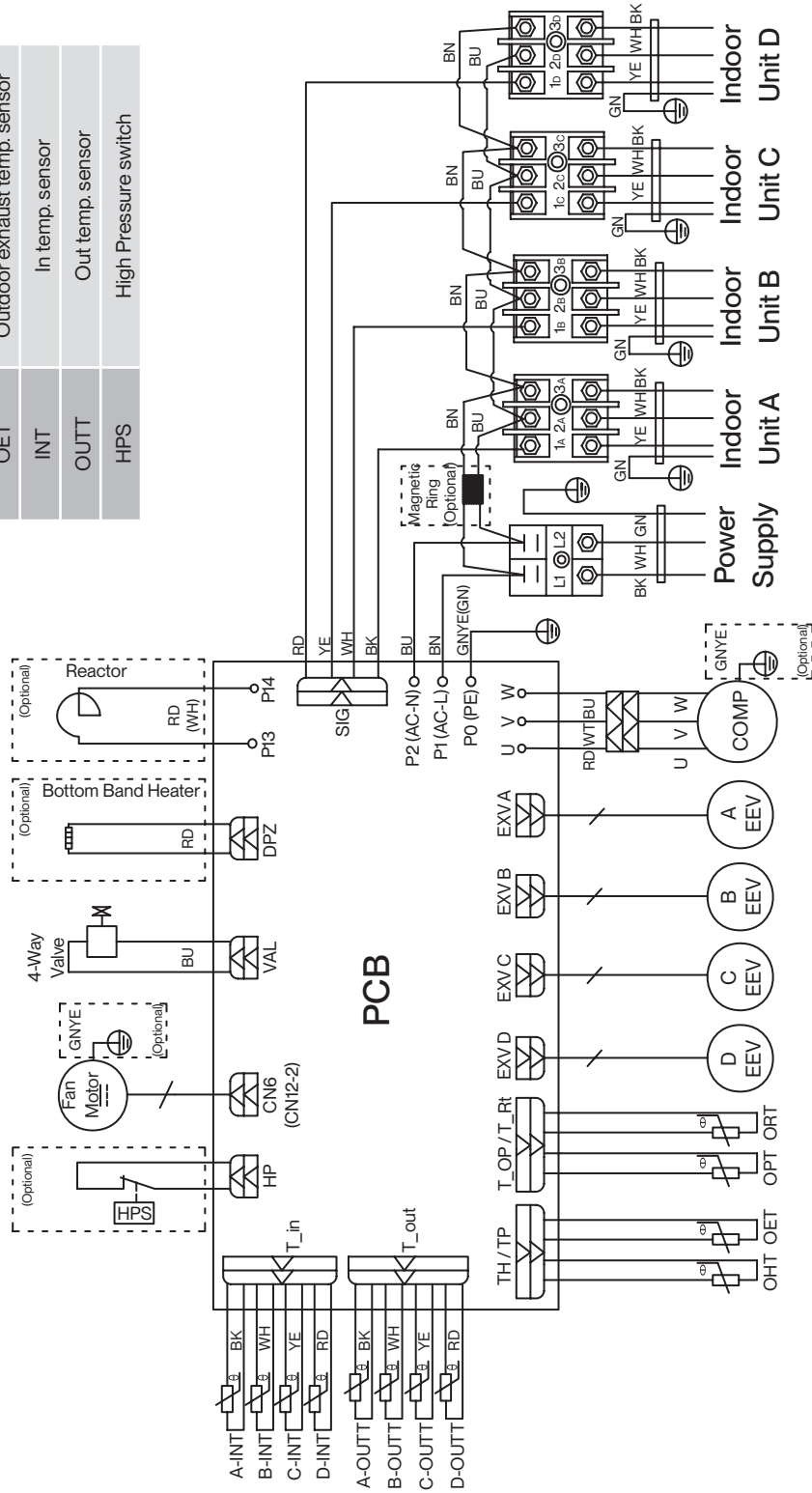

Outdoor Unit Installation

Outdoor Unit Circuit Diagram

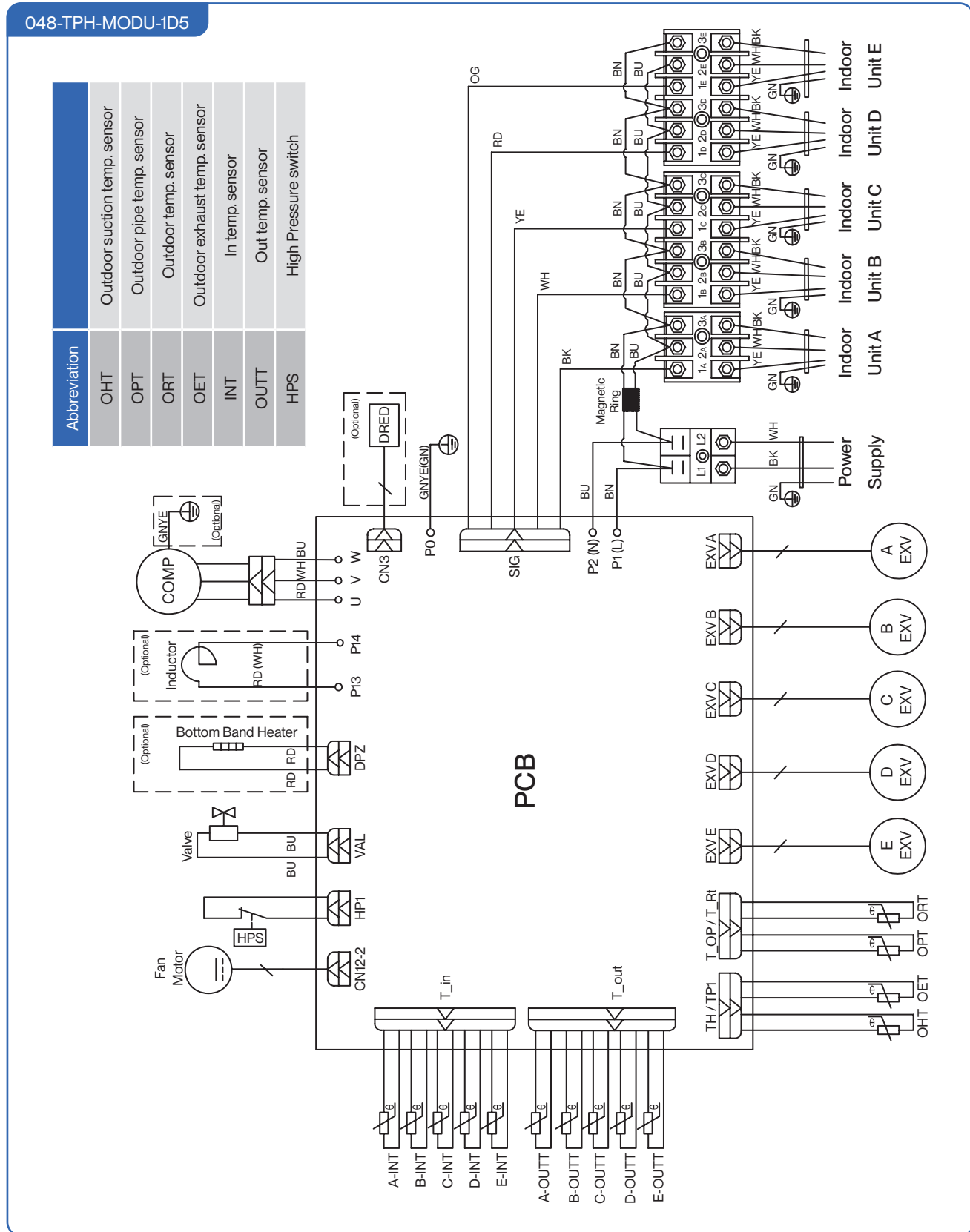

Outdoor Unit Installation

Vacuum Pumping

Della multi-zone mini split AC system require vacuum evacuation before operation.

Vacuuming the refrigerant lineset removes air moisture that the refrigerant can react with and damage internal components and reduce system efficiency.

Depending on the number of zones your system supports, different evacuation methods may be required.

Follow these instructions carefully and select the method best suited for your installation.

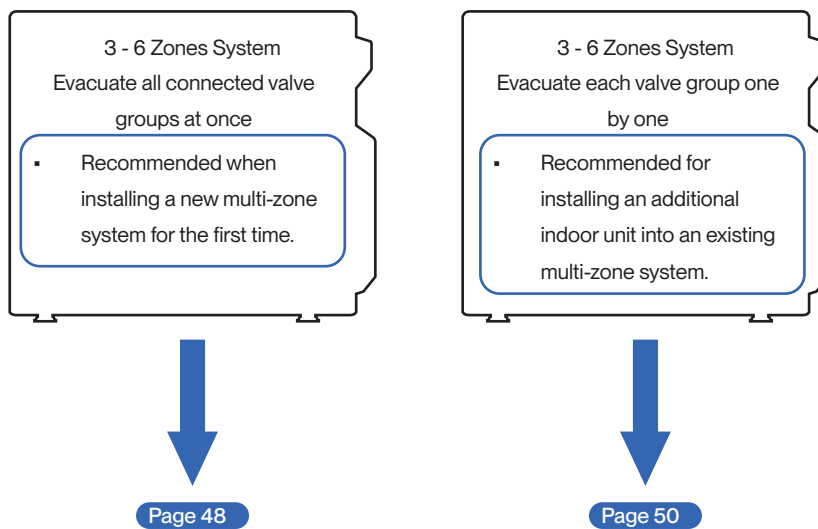

Outdoor Unit Installation

Vacuum Pumping Tools Set Up

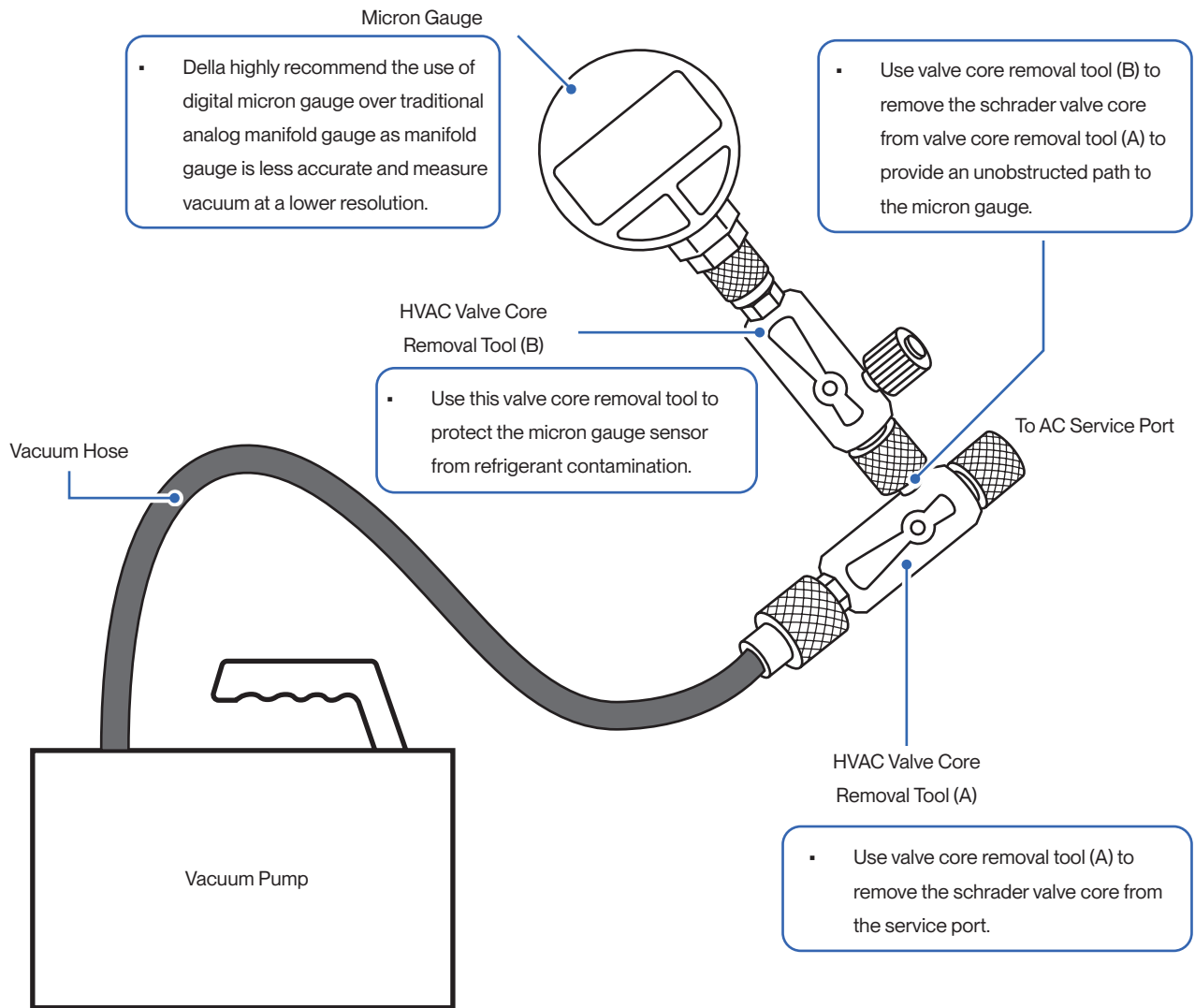

WARNING

- When evacuating mini-split system with A2L rated refrigerant, an A2L rated vacuum pump must be used. If an A2L rated pump is not available, vacuuming must be done outdoor only. Failure to follow this instruction may result in fire or explosion hazard.

Outdoor Unit Installation (3-6 Zones System with Master Valve)

Vacuum Pumping, Leak Test (Using Micron Gauge) *RECOMMENDED, and Adjust Refrigerant Level

1. Remove the protective caps from the master service port, and from all the low pressure valves (Lo-R) that has a indoor unit connected.
2. Remove schrader valve core from the master service port using valve core removal tool.
3. Connect valve core removal tool (A) to the master service port.
4. Connect one end of the vacuum hose to the vacuum pump, and the other end to valve core removal tool (A).
5. Connect micron gauge onto valve core removal tool (B) and then connect to the side port of valve core removal tool (A).
6. OPEN both ball valves on valve core removal tool (A) and (B).
7. OPEN the low pressure valves.



- ONLY open the low pressure valves, DO NOT open the high pressure valves.

8. Turn on the vacuum pump and run until the micron gauge indicate the value of 500 micron or lower. (Ideally close to 350)
9. CLOSE the ball valve on valve core removal tool (A) and turn OFF the vacuum pump. Let the vacuum pressure settle for at least 5 minutes. Ensure the gauge reading does not exceed 500 microns.



- You must leave the micron gauge and vacuum pump connected for a short period after vacuuming the system and check for a successful deep vacuum in order to make sure there is no leak and no contaminants inside the refrigerant lineset.
- In the case of the gauge reading exceeding 500, which indicate a leak, check and re-tighten all connection. Then perform vacuuming again.

10. CLOSE the ball valve on valve core removal tool (B).
11. OPEN all the connected high pressure valve (Hi-R) for 1/4 turn for 5 seconds, and CLOSE the high pressure valve (Hi-R) again.

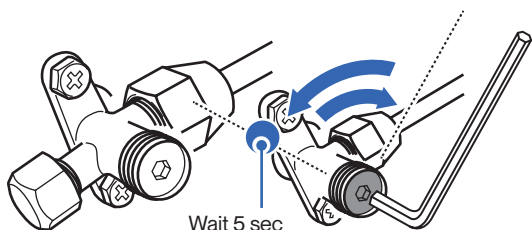

- ONLY open high pressure valves that has a connected unit.

12. Disconnect the vacuum hose and insert the schrader valve back into the valve core removal tool (A). Make sure the end cap is tightly sealed and then open the ball valve on valve core removal tool (A).
13. Reinstall the schrader valve into the service port.
14. Disconnect the valve core removal tools from the service port.
15. The outdoor unit comes with enough refrigerant for the standard length refrigerant pipe set. Add refrigerant charge if you use a longer refrigerant line. [Page 14](#)
16. Fully open the high pressure valves (Hi-R), following by the low pressure valves (Lo-R) that has a connected unit.
17. Fully open the master valve.
18. Reattach all protective caps back on the master service port, low pressure valves and high pressure valves.
19. Reattach the valve cover on the outdoor unit.



- Only add refrigerant if you use a lengthened refrigerant line. There is no need to adjust or recover any amount refrigerant if you use a standard or shortened refrigerant line.
- Do not open the refrigerant valve before vacuum pumping.
- Stop and disconnect the vacuum pump from the system before fully opening the refrigerant valve.
- Master valve must be opened after evacuation for the system to perform properly.

Additional Refrigerant

- Additional Refrigerant Amount (ounce)
 $[0.11 \times (\text{Total install length (ft)} - \text{Supported zones no.} \times 25)] \text{ oz}$
- Additional Refrigerant Amount (gram)
 $[10 \times (\text{Total install length (m)} - \text{Supported zones no.} \times 7.5)] \text{ g}$
- Example 1:
 A total of 150ft of pipe line is installed for a 5 zones system,
 $[0.11 \times (150 - 5 \times 25)] \text{ oz}$
 $= [0.11 \times (150 - 125)] \text{ oz}$
 $= 2.75 \text{ oz of additional refrigerant}$
- Example 2:
 A total of 60ft of pipe line is installed for a 3 zones system,
 $[0.11 \times (60 - 3 \times 25)] \text{ oz}$
 $= [0.11 \times (60 - 75)] \text{ oz}$
 $= -1.65 \text{ oz}$
 $= \text{NO additional refrigerant needed when getting NEGATIVE value.}$

Outdoor Unit Installation (3-6 Zones System with Master Valve)

Micron Gauge Connection

- Before vacuum pumping, make sure all refrigerant pipings are connected.
- It is recommended to perform a nitrogen leak check on all refrigerant joints.
- Check if all wiring is connected.

- Master valve must be opened after evacuation for the system to perform properly.

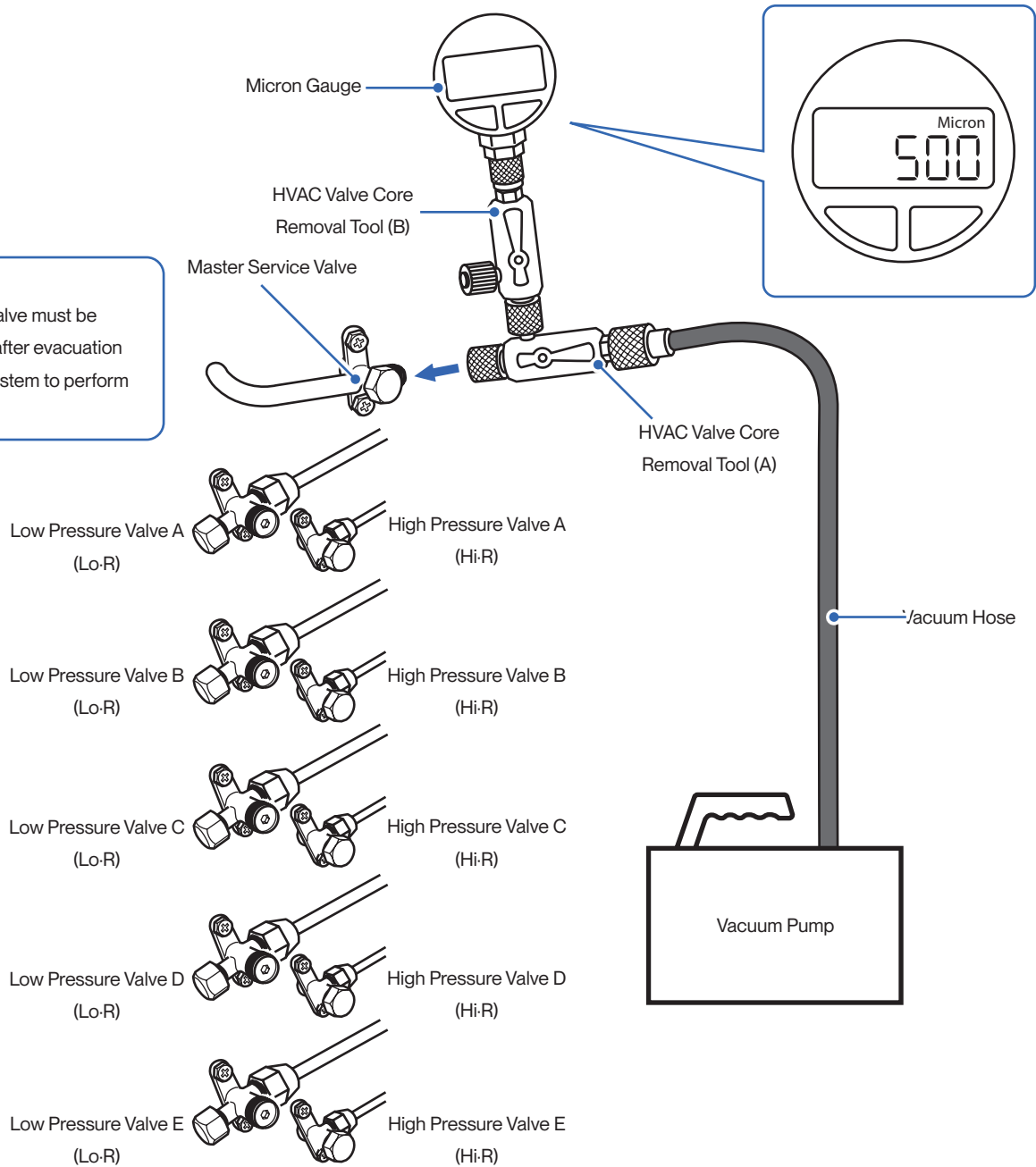

Outdoor Unit Installation (3-6 Zones System, Adding New Indoor Unit)

Vacuum Pumping, Leak Test (Using Micron Gauge) *RECOMMENDED, and Adjust Refrigerant Level

1. Remove the protective caps from the service port, low pressure valve (Lo-R), and high-pressure valve (Hi-R) on the valve group with a newly added indoor unit.
2. Remove schrader valve core from the service port using valve core removal tool.
3. Connect valve core removal tool (A) to the service port.
4. Connect one end of the vacuum hose to the vacuum pump, and the other end to valve core removal tool (A).
5. Connect micron gauge onto valve core removal tool (B) and then connect to the side port of valve core removal tool (A).
6. OPEN both ball valves on valve core removal tool (A) and (B).
7. Turn on the vacuum pump and run until the micron gauge indicate the value of 500 micron or lower. (Ideally close to 350)
8. CLOSE the ball valve on valve core removal tool (A) and turn OFF the vacuum pump. Let the vacuum pressure settle for at least 5 minutes. Ensure the gauge reading does not exceed 500 microns.
9. CLOSE the ball valve on valve core removal tool (B).
10. OPEN the high pressure valve (Hi-R) for 1/4 turn for 5 seconds, and CLOSE the high pressure valve (Hi-R) again.
11. Disconnect the vacuum hose and insert the schrader valve back into the valve core removal tool (A). Make sure the end cap is tightly sealed and then open the ball valve on valve core removal tool (A).
12. Reinstall the schrader valve into the service port.
13. Disconnect the valve core removal tools from the service port.
14. The outdoor unit comes with enough refrigerant for the standard length refrigerant pipe set. Add refrigerant charge if you use a longer refrigerant line. [Page 14](#)
15. Fully open the high pressure valve (Hi-R), following by the low pressure valve (Lo-R) on the valve group of the newly added indoor unit.
16. Reattach all protective caps back on the service port, low pressure valve and high pressure valve.
17. Reattach the valve cover on the outdoor unit.



- You must leave the micron gauge and vacuum pump connected for a short period after vacuuming the system and check for a successful deep vacuum in order to make sure there is no leak and no contaminants inside the refrigerant lineset.
- In the case of the gauge reading exceeding 500, which indicate a leak, check and re-tighten all connection. Then perform vacuuming again.



- Only add refrigerant if you use a lengthened refrigerant line. There is no need to adjust or recover any amount refrigerant if you use a standard or shortened refrigerant line.
- Do not open the refrigerant valve before vacuum pumping.
- Stop and disconnect the vacuum pump from the system before fully opening the refrigerant valve.
- Each newly added indoor unit connected into an existing multi-zone system must vacuumed respectively.

9. CLOSE the ball valve on valve core removal tool (B).
10. OPEN the high pressure valve (Hi-R) for 1/4 turn for 5 seconds, and CLOSE the high pressure valve (Hi-R) again.

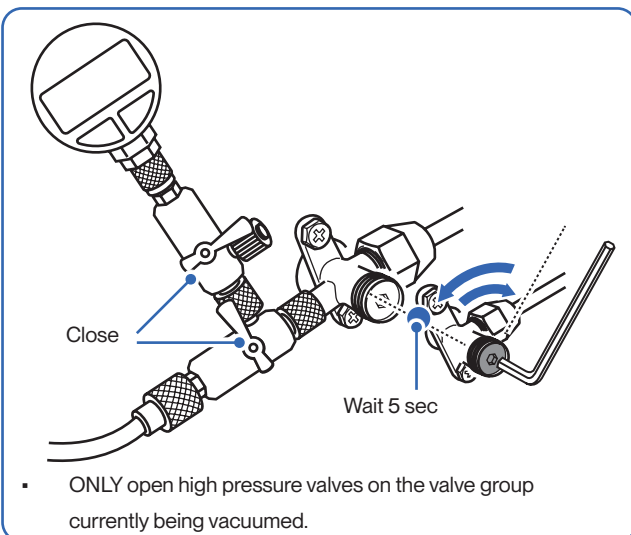

Additional Refrigerant

- Additional Refrigerant Amount (ounce)
 $[0.11 \times (\text{Total install length (ft)} - \text{Supported zones no.} \times 25)] \text{ oz}$
- Additional Refrigerant Amount (gram)
 $[10 \times (\text{Total install length (m)} - \text{Supported zones no.} \times 7.5)] \text{ g}$
- Example 1:
 A total of 150ft of pipe line is installed for a 5 zones system,
 $[0.11 \times (150 - 5 \times 25)] \text{ oz}$
 $= [0.11 \times (150 - 125)] \text{ oz}$
 $= 2.75 \text{ oz of additional refrigerant}$
- Example 2:
 A total of 60ft of pipe line is installed for a 3 zones system,
 $[0.11 \times (60 - 3 \times 25)] \text{ oz}$
 $= [0.11 \times (60 - 75)] \text{ oz}$
 $= -1.65 \text{ oz}$
 $= \text{NO additional refrigerant needed when getting NEGATIVE value.}$

Outdoor Unit Installation (3-6 Zones System, Adding New Indoor Unit)

! Master valve has been fully opened on the existing operational system. There is no need to close the master valve when evacuating a newly added indoor unit valve group.

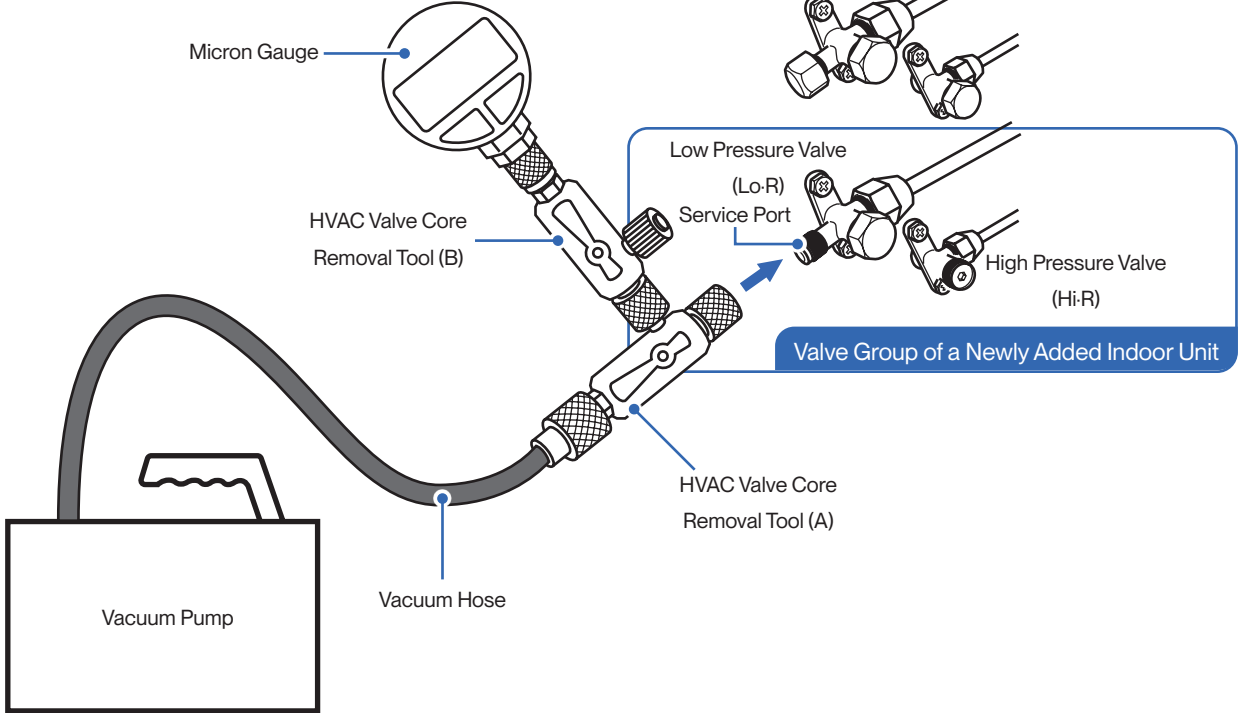
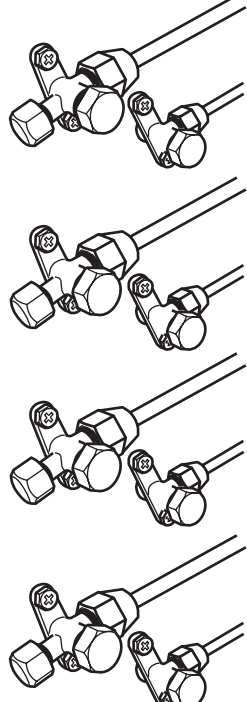
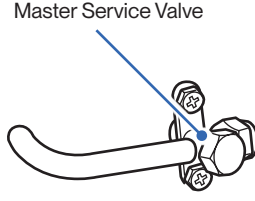

Finishing

Line Set Insulation, Bundling, and Finishing Touch

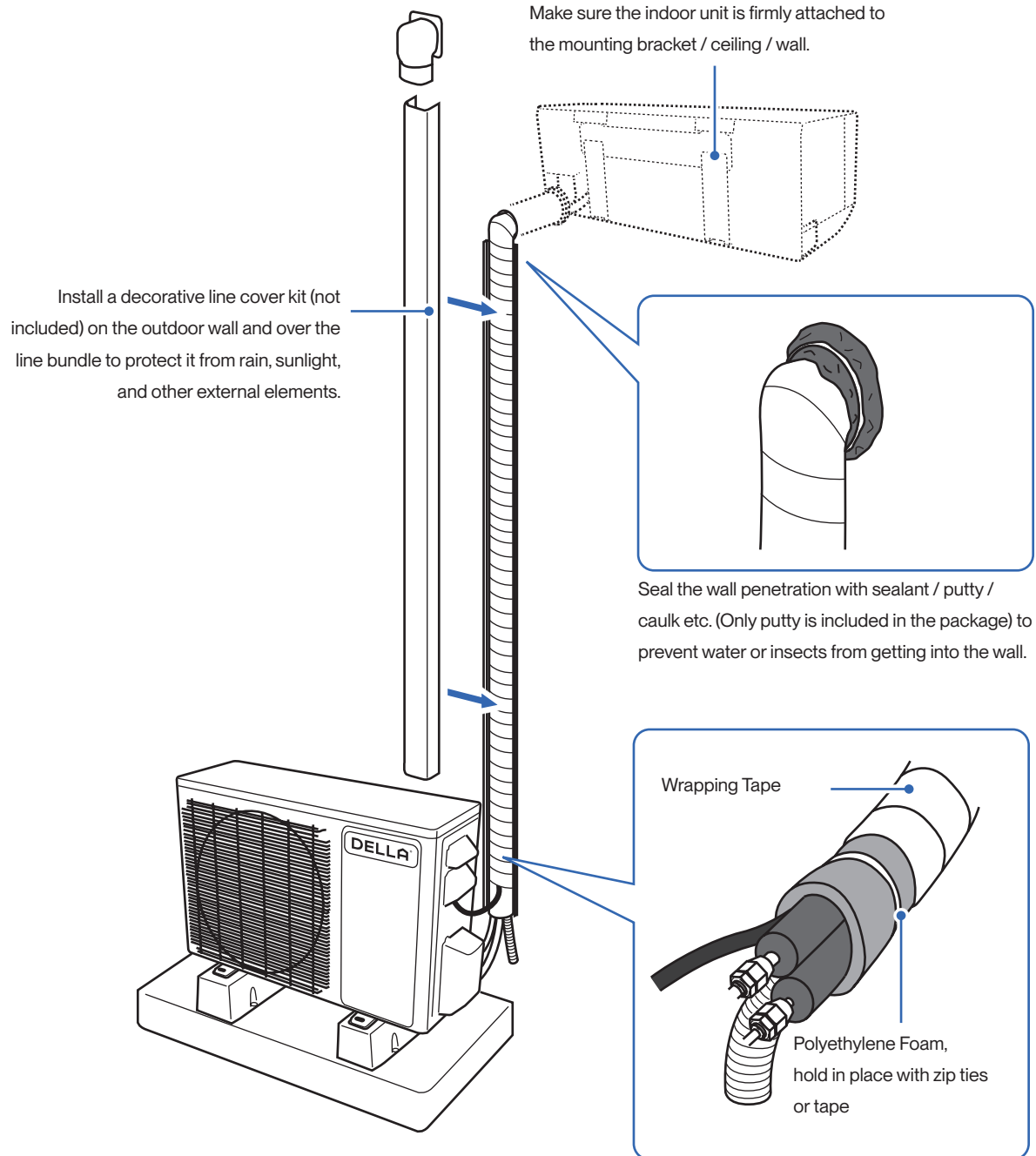

QUICK TIPS

- When wrapping and bundling the line set, avoid over tightening to prevent the insulating materials from over compression.
- Make sure all connection joints are properly insulated.

Finishing

Check List

Go through the following list and check your installation.

the check box for each confirmation.

Check List	Status
Are the indoor and outdoor unit kept at least the minimum distance away from the closest wall and obstacle?	<input type="checkbox"/>
Is the indoor unit securely mounted?	<input type="checkbox"/>
Are all the panels on the unit secured and would not fall out?	<input type="checkbox"/>
Is the drain hose properly attached?	<input type="checkbox"/>
Are the refrigerant pipes securely connected and no refrigerant leakage?	<input type="checkbox"/>
Are the refrigerant pipes and electrical cables from each indoor unit connected to their corresponding ports? (e.g. Indoor unit A connecting to refrigerant valve A and electrical terminal A on the outdoor unit)	<input type="checkbox"/>
Are all pipes, hoses, and cable bundled and wrapped with insulation tape?	<input type="checkbox"/>
Is the system properly vacuumed?	<input type="checkbox"/>
Is all the wall opening sealed off?	<input type="checkbox"/>
Are the refrigerant valves fully opened?	<input type="checkbox"/>
Do the power supply and voltage match the unit rating? (Check before connecting to power supply)	<input type="checkbox"/>
Is the electrical wiring in the unit connected and secured?	<input type="checkbox"/>
Are the units properly grounded?	<input type="checkbox"/>
Is the power breaker, fuse, or protection device installed?	<input type="checkbox"/>
Can the remote control send control commands to the air conditioner?	<input type="checkbox"/>



- Any failures, accidents, or damages caused by improper installation are not covered by the warranty.

Finishing

Test Run

After the installation, test run the mini split system and take sure it performs and works properly without water leak or abnormal noise.

1. Turn on the power supply.
2. Turn on the air conditioner using the remote control.
3. Test the unit at the lowest temperature in COOL mode.
4. Test the unit at the highest temperature in HEAT mode.
5. Test each mode for at least 8 minutes.
 - Measure the air temperature at the air outlet.
 - Check if water drains properly from the drainage hose.
 - Check if the louver and deflectors move properly.
6. If everything is operating normally, return to normal setting and turn off the air conditioner.
7. Inform the user to read the operation instruction before use, and demonstrate to the user how to use the air conditioner, the necessary knowledge of service and maintenance, and a reminder of accessories storage.



- Wait for at least 2 hours before turning on the air conditioner after installation. Make sure the air conditioner is powered during the wait time and let the system to balance the refrigerant pressure and calibrate sensors.
- When switching between COOL mode and HEAT mode, the system might takes about 3 - 5 minutes due to an internal protection system.



- If the ambient temperature exceed the normal operation range, lift the front panel and use the emergency button to run COOL and HEAT modes.



Contact us if you encounter any problems during or after the installation.



support.dellahome.com



800-863-4143
6:00 a.m. - 4:00 p.m. PST
Monday - Friday



24/7 Live Chat

Warranty



Scan the QR code or visit our page on dellahome.com/pages/warranty to sign up for warranty coverage on your new DELLA appliance.



dellahome.com/pages/warranty



Compliance Information

Radio Frequency Interference



Model: 048-TPH-MODU series

FCC Caution

This device complies with part 15 of the FCC Rules. Operation is subject to the following two conditions:

(1) This device may not cause harmful interference, and (2) this device must accept any interference received, including interference that may cause undesired operation. Any changes or modifications not expressly approved by the party responsible for compliance could void the user's authority to operate the equipment.

NOTE: This equipment has been tested and found to comply with the limits for a Class B digital device, pursuant to Part 15 of the FCC Rules. These limits are designed to provide reasonable protection against harmful interference in a residential installation. This equipment generates, uses and can radiate radio frequency energy and if not installed and used in accordance with the instructions, may cause harmful interference to radio communications. However, there is no guarantee that interference will not occur in a particular installation. If this equipment does cause harmful interference to radio or television reception, which can be determined by turning the equipment off and on, the user is encouraged to try to correct the interference by one or more of the following measures:

- Reorient or relocate the receiving antenna.
- Increase the separation between the equipment and receiver.
- Connect the equipment into an outlet on a circuit different from that to which the receiver is connected.
- Consult the dealer or an experienced radio / TV technician for help.

Memo

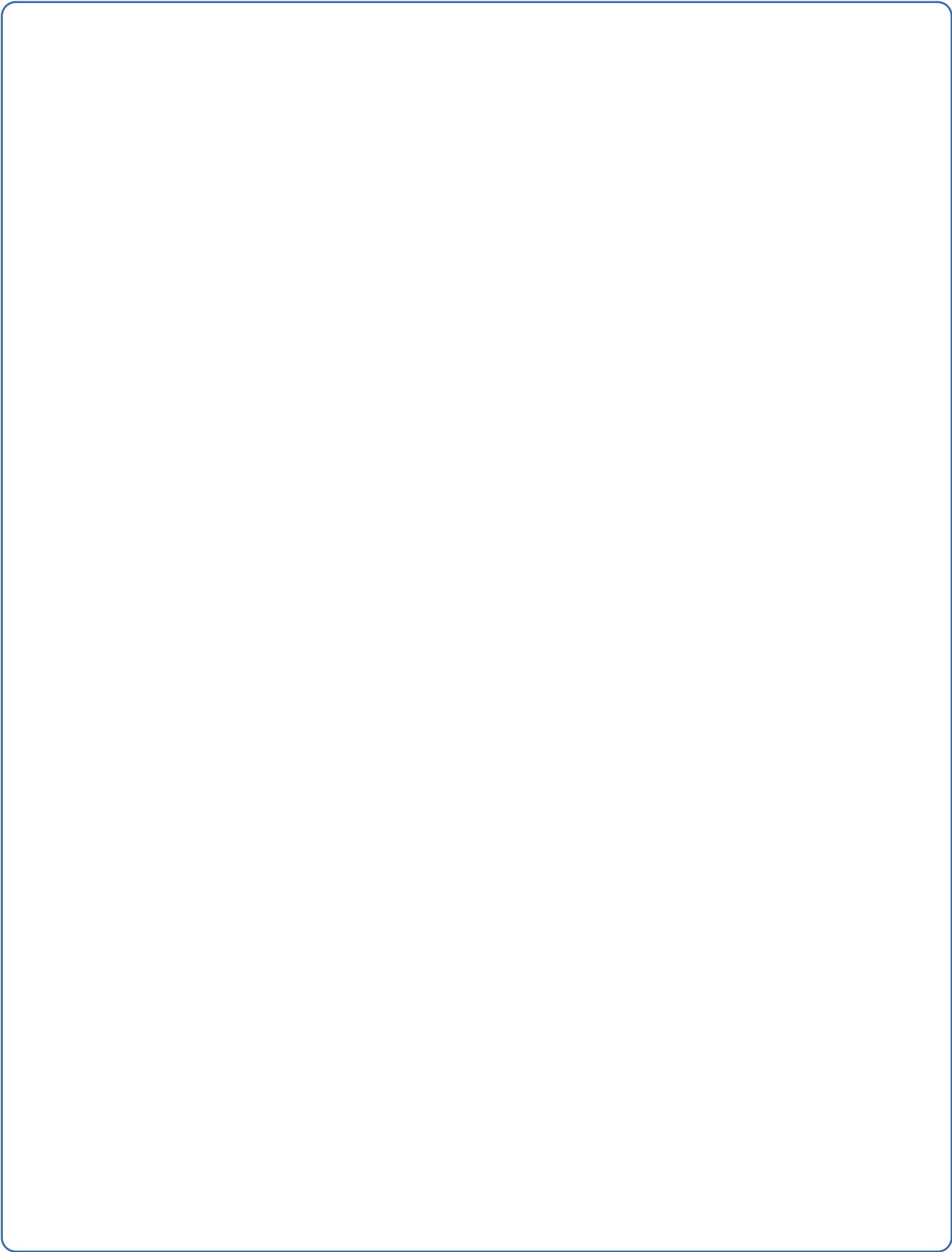

Memo



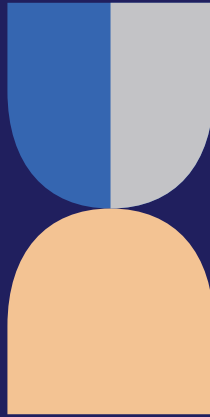

 www.dellahome.com

 support@dellahome.com

 800-863-4143

 6:00 a.m. – 4:00 p.m. PST Monday – Friday

© Della All rights reserved.

The design and specifications are subject to change without prior notice for product improvement. Any updates to the manual will be uploaded to the della website.
